

A1363 Programmable Linear Hall-Effect IC

可编程线性霍尔 IC A1363

- 可编程线性砷化镓与硅基混合霍尔 IC
GaAs + Si Hybrid Programmable Linear Hall-Effect IC
- 3V~5.5V 供电电压范围
Single power supply: VCC 3V ~ 5.5V
- 可编程固定输出或比例输出模式，兼具参考电压输出
Fixed or Ratiometric Output
- -40~125°C 使用环境
Wide ambient Temperature Range : Ta -40°C ~ 125°C
- 快速响应兼具宽带宽
Quick response for magnetic field with wide bandwidth
- 提供可编程单线通信接口
Programmable via One Wire Interface at VOUT Pin
- 可通过编程改变灵敏度方向
Sensitivity direction can be changed programmatically

引脚定义 Pinning Define

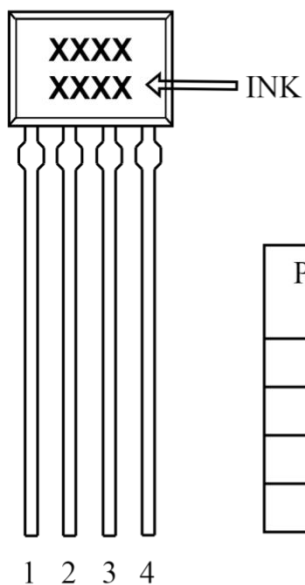

Pinning 引脚	Pinning Define 引脚定义
1	VCC
2	GND
3	VOUT
4	VREF

应用场景 Application scenario

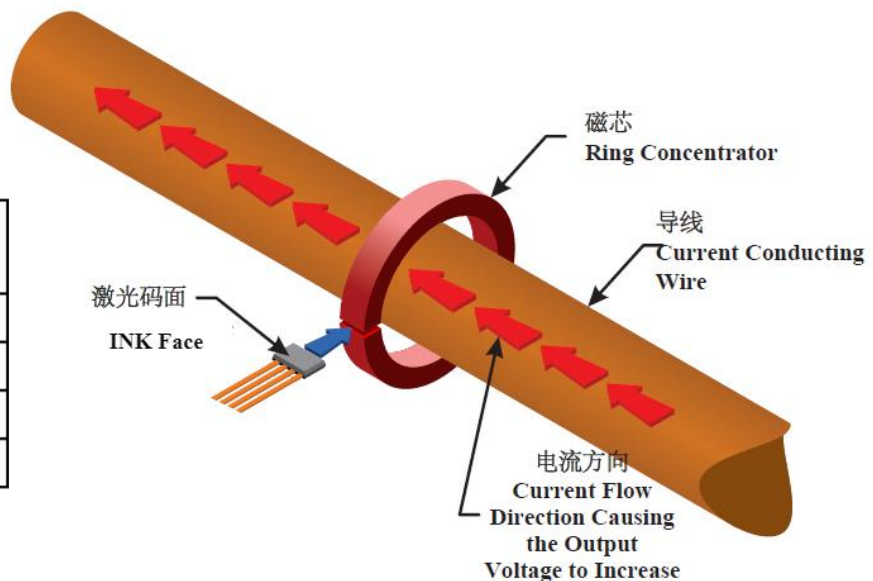

外形尺寸图 Dimensional Drawing (Unit MM)

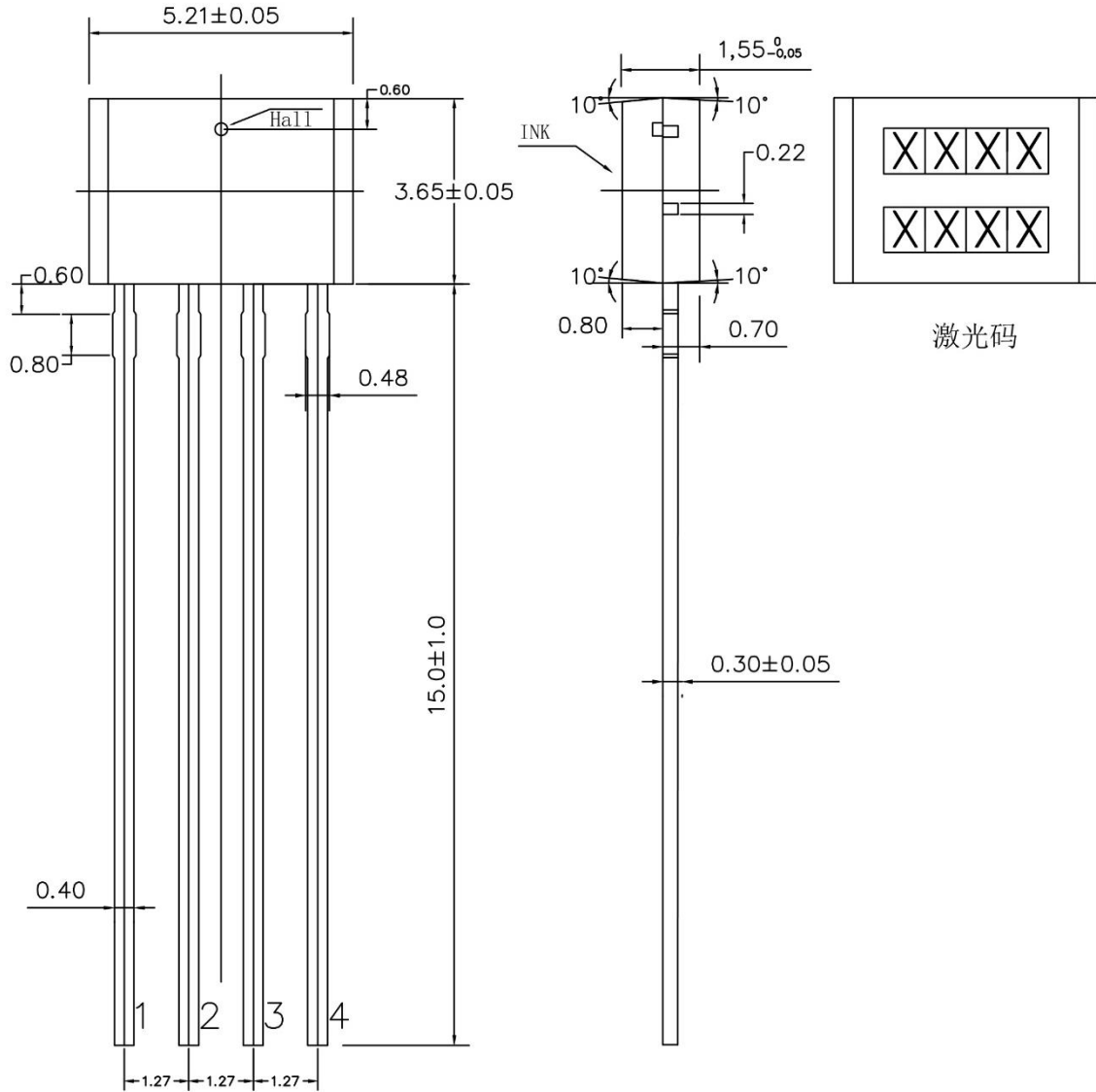

主视图 Main view

右视图 Right view

底视图 Bottom view

备注 Note:

未标识的尺寸公差为 ± 0.05 mm，角度的公差为 $\pm 1^\circ$

Unmarked tolerances are controlled according to ± 0.05 mm while the Angle tolerance is $\pm 1^\circ$.

最大绝对参值 Absolute Maximum Rating

Table 1. A1363 Working conditions

特性 Characteristics	符号 Symbol	条件 Condition	最小值 Min	标准值 Typ	最大值 Max	单位 Unit
输入电压 Supply Voltage	VCC	T _a = 25°C	-0.3		6.5	V
输出电流 Output Current	I _{out}	T _a = 25°C	-45		45	mA
输出电压 Output Voltage	V _{out}	T _a = 25°C	0.1		VCC-0.1	V
存储温度 Storage Temp.	T _s		-40		150	°C
工作温度 Operation Temp.	T _a		-40		125	°C

工作参数 Operation Conditions

Table 2. Electric and magnetic characteristics Ta=-40 to 125°C

特性 Characteristics	符号 Symbol	条件 Condition	最小值 Min	标准值 Typ	最大值 Max	单位 Unit
供电电压 Supply Voltage	V _{CC}	T _a = 25°C	3	3.3V/5V	5.5	V
电流 Current Consumption	I _{CC}	In Programming @ T _a = 25°C	-		33	mA
		In normal operation @T _a =25°C	-	6/8	11	mA
可编程灵敏度范围 Sensitivity Range	Sens	T _a = 25°C	0.1		100	mV/GS
响应时间 Response Time	T _r ^②	C=20pF@ BW=600kHz, T _a = 25°C	-	1	-	μs
		C=20pF@ BW=500kHz, T _a = 25°C	-	1.5	-	
		C=20pF@ BW=250kHz, T _a = 25°C	-	2	2.5	
		C=20pF@ BW=50kHz, T _a = 25°C	-	4.5	-	
信号带宽 Signal bandwidth	B _w		-	250	500	KHz
负载电容 Load Capacitance	C _L	T _a = 25°C	-	20p	10n	F
参考电压 Reference Voltage @T _a =25°C	V _{ref}	S ^③	2.470		2.530	V
		SS ^③	2.490		2.510	
零点输出 Quiescent Voltage	V ₀	VCC=5V@25°C	2.495	2.500±0.002	2.505	V
		VCC=3.3V@25°C	1.645	1.650±0.002	1.655	
差分零点输出 Quiescent Voltage of Differential Output ^④ at T _a 25°C	V ₀ -V _{ref}	VCC=5V@-40~125°C	-0.01	±0.005	0.01	V
		VCC=3.3V@-40~125°C	-0.005	±0.002	0.005	V
灵敏度温漂 Sensitivity drift through temperature	Sens _{TC}	-40°C~125°C	-1.5	±0.5	1.5	%
输出饱和电压 Output Saturation Voltage	V _{out-SatH}				VCC-0.1	V
	V _{out-SatL}		0.1			
灵敏度比率误差 Error of sensitivity	Rat _{ERR} Sens	VCC in range 4.85~5.15V @-40~125°C	-0.5		0.5	%
零点比率误差 Error of Quiescent Voltage	Rat _{ERR} V ₀	VCC in range 4.85~5.15V @-40~125°C	-0.5		0.5	%
线性误差 Linearity Error	Lin _{ERR}	VCC=5V@-40~125°C	-0.5	±0.1	0.5	%

固定输出模式 Fixed Output Mode[®]:

参考电压温漂 Reference Voltage drift through temperature	ΔV_{ref}	VCC=5V@-40~125°C	-0.03	±0.02	0.03	V
		VCC=3.3V@-40~125°C	-0.02	±0.015	0.02	
零点温漂 Quiescent Voltage drift through temperature	ΔV_0	VCC=5V@-40~125°C	-0.03	±0.02	0.03	V
		VCC=3.3V@-40~125°C	-0.02	±0.015	0.02	
差分零点温漂 Quiescent Voltage of Differential Output drift through temperature	$\Delta (V_0 - V_{ref})$	VCC=5V@-40~125°C	-0.02	±0.01	0.02	V
		VCC=3.3V@-40~125°C	-0.01	±0.007	0.01	

比例输出模式 Ratiometric Output Mode[®]:

参考电压温漂 Reference Voltage drift through temperature	ΔV_{ref}	VCC=5V@-40~125°C	-0.01	±0.005	0.01	V
		VCC=3.3V@-40~125°C	-0.007	±0.005	0.007	
零点温漂 Quiescent Voltage drift through temperature	ΔV_0	VCC=5V@-40~125°C	-0.01	±0.005	0.01	V
		VCC=3.3V@-40~125°C	-0.007	±0.005	0.007	
差分零点温漂 Quiescent Voltage of Differential Output drift through temperature	$\Delta (V_0 - V_{ref})$	VCC=5V@-40~125°C	-0.02	±0.005	0.02	V
		VCC=3.3V@-40~125°C	-0.01	±0.005	0.01	

Note:

- ① 当灵敏度超出 20mV/GS 后，响应时间会超出 2us
When the sensitivity exceeds 20mV/GS, the response time is greater than 2us
- ② 响应时间可通过编程控制
Response time can be controlled programmatically
- ③ S 与 SS 代表芯片的不同档位
S and SS represent different gears of the chip
- ④ 固定输出模式：输出电压不随供电电压波动
Fixed output mode: The output voltage does not fluctuate with the supply voltage
- ⑤ 比例输出模式：输出电压随供电电压波动
Ratiometric mode: Output voltage fluctuates with the supply voltage
- ⑥ 差分输出：

$$\text{差分零点输出} = V_0 - V_{ref}$$

$$\text{差分灵敏度} = \frac{V_{OUT}(B) - V_{ref}}{B}$$

Differential Output: Quiescent Voltage output is equal to V0 subtract Vref while Magnetized Output is equal to Vout (B) subtract Vref

- ⑦ 零点和灵敏度可分别设置为是否随电压变化
Static voltage and sensitivity can be set to vary with or without voltage, respectively

特性定义 Characteristics Definitions

1. Sens 【mV/GS】灵敏度 Sensitivity

灵敏度定义为磁感应输出与磁感应强度的比值，即加磁输出减去零点输出后的数值与磁感应强度的比值

Sensitivity is defined as the slope of the approximate straight line calculated by the least square method, using data of OUT voltage (Vout) when the magnetic flux density (B) is swept within the range of input magnetic flux density (Bin).

$$\text{Sens} = \frac{V_{\text{OUT}}(B) - V(0)}{B}$$

2. Sens_{TC} 【%】灵敏度温漂 Sensitivity drift through temperature

灵敏度温漂定义为温度导致的灵敏度变化值与校准温度（常温 25℃）下的灵敏度的比值

Sensitivity temperature drift is defined as the ratio of the value of the sensitivity change due to temperature to the sensitivity at the calibrated temperature (25℃).

$$\text{Sens}_{\text{TC}} = \frac{\Delta \text{Sens}}{\text{Sens}(25^\circ\text{C})} * 100 = \frac{\text{Sens}(T) - \text{Sens}(25^\circ\text{C})}{\text{Sens}(25^\circ\text{C})} * 100$$

3. Lin_{ERR} 【%】线性误差 Linearity Error

线性误差定义为最大垂直偏差（MFD）与最大量程（F.S.）的比值

最大垂直偏差（MFD）指得是实际输出与拟合输出曲线的在同一磁感应强度下的最大误差即 Vout (B 实际) - Vout (B 拟合)。定义公式如下所示：

Linearity error is defined as the ratio of the maximum perpendicular deviation (MFD) to the full scale (F.S.), where MFD is the maximum difference between the OUT voltage (Vout) and the approximate straight line calculated in the sensitivity definition. Definition formula is shown in below:

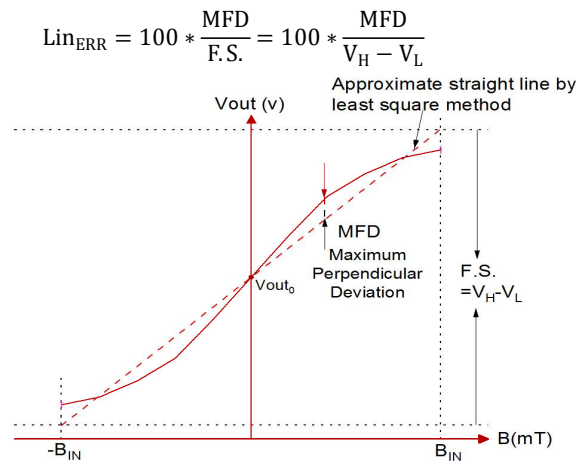

Figure 1. Output characteristics of A1363

4. 灵敏度比率误差 Rat_{ERR}Sens [%]以及零点比率误差 Rat_{ERR}V₀ [%]（仅对比例输出模式有效）

Ratiometric output error of sensitivity Rat_{ERR}Sens [%] and ratiometric output error of Quiescent voltage Rat_{ERR}V₀ [%] (Only valid for proportional output mode).

A1363 器件具有比例输出。这意味着静态电压输出（V₀）和磁灵敏度（Sens）与电源电压（VCC）成正比。换句话说，当电源电压增加或减少一定百分比时，每个特性也增加或减少相同的百分比。误差是测量到的相对于 5v 的电源电压变化与测量到的每个特性变化之间的差值。

The A1363 device features ratiometric output. This means that the Quiescent Voltage Output, V₀, magnetic

sensitivity, Sens are proportional to the Supply Voltage, VCC. In other words, when the supply voltage increases or decreases by a certain percentage, each characteristic also increases or decreases by the same percentage. Error is the difference between the measured change in the supply voltage relative to 5 V, and the measured change in each characteristic.

$$\text{Rat}_{\text{ERR Sens}} = \left[1 - \frac{V_{\text{out}}(\text{VCC})}{V_{\text{out}}(5\text{V})} * \frac{5\text{V}}{\text{VCC}} \right] * 100$$

$$\text{Rat}_{\text{ERR V0}} = \left[1 - \frac{V_0(\text{VCC})}{V_0(5\text{V})} * \frac{5\text{V}}{\text{VCC}} \right] * 100$$

5. T_r [μs] 上升响应时间 Rise response time

响应时间定义为在磁感应强度脉冲输入下，从输入磁场的 90%到输出电压的 90%的时间延迟。

Rise response time is defined as the time delay from the 90% of input magnetic field (B) to the 90% of the OUT voltage (Vout) under the pulse input of magnetic flux density.

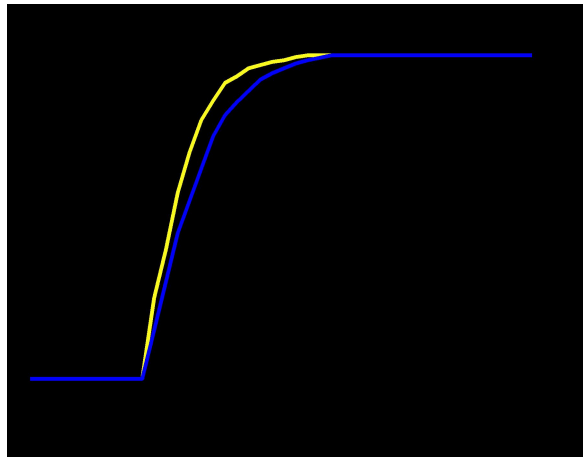

Figure 2. Definition of response time

6. $V_{\text{out-SatH}}$ 、 $V_{\text{out-SatL}}$ 饱和输出电压 Saturation Output Voltage

输出可以随着磁场强度的变化在最大值 $V_{\text{SAT(HIGH)}}$ 和最小值 $V_{\text{SAT(LOW)}}$ 之间摆动。

The output can oscillate between the maximum $V_{\text{out-SatH}}$ and minimum $V_{\text{out-SatL}}$ as the magnetic field strength changes.

7. Sym_{ERR} 【%】灵敏度对称性误差 Symmetry Sensitivity Error

器件在任意两个大小相等、极性相反磁场下的灵敏度是大小相等的。

The magnetic sensitivity of device is constant for any two applied magnetic fields of equal magnitude and opposite polarities. Sym_{ERR} (%) is measured and defined as:

$$\text{Sym}_{\text{ERR}} = \left(1 - \frac{\text{Sens}_{\text{BPOS}}}{\text{Sens}_{\text{BNEG}}} \right) * 100\%$$

输出特性 Output Characteristics

1. 零点温漂和参考电压温漂 Static voltage temperature drift and reference voltage temperature drift
- 2.1 固定输出模式 Fixed Output Mode (Sens=10mV/GS、B=200GS、V0=2.5V)
 - 2.1.1 ΔV_0 零点温漂 Quiescent Voltage drift through temperature

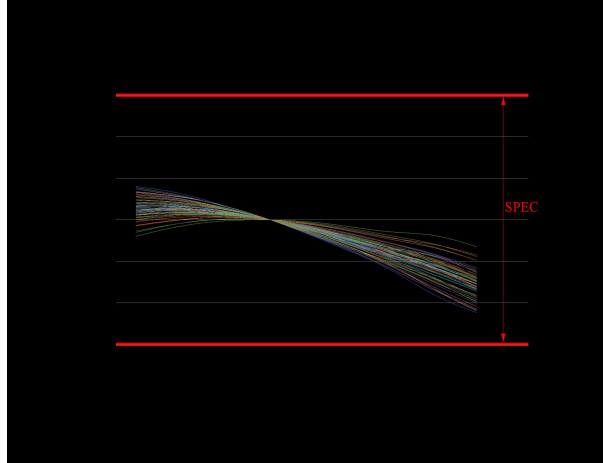

2.1.2 ΔV_{ref} 参考电压温漂 Reference Voltage drift through temperature

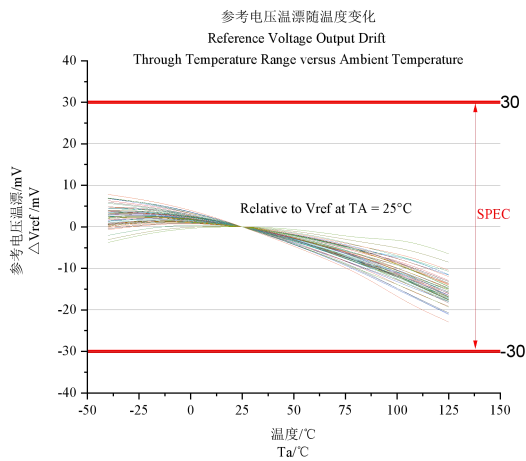

2.1.3 开启/关闭电压 Power On /Off

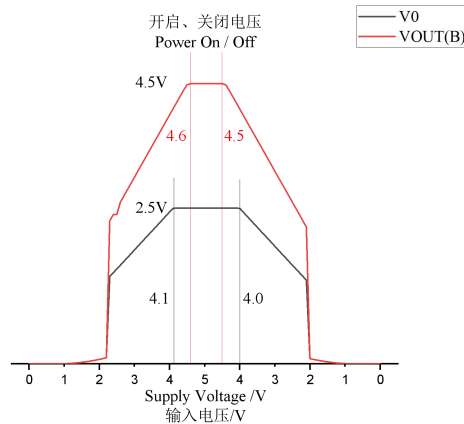

2.2 比例输出模式 Ratiometric Output Mode (Sens=10mV/GS、B=200GS、V0=1/2VCC)

2.2.1 ΔV_0 零点温漂 Quiescent Voltage drift through temperature

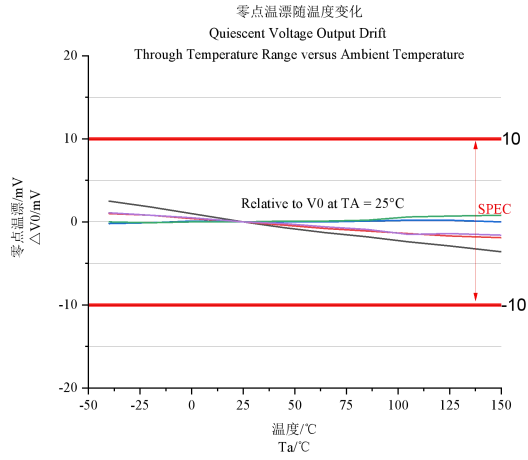

2.2.2 ΔV_{ref} 参考电压温漂 Reference Voltage drift through temperature

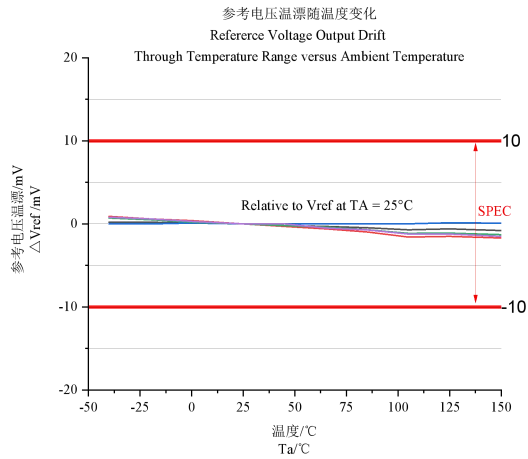

2.2.3 开启/关闭电压 Power On /Off

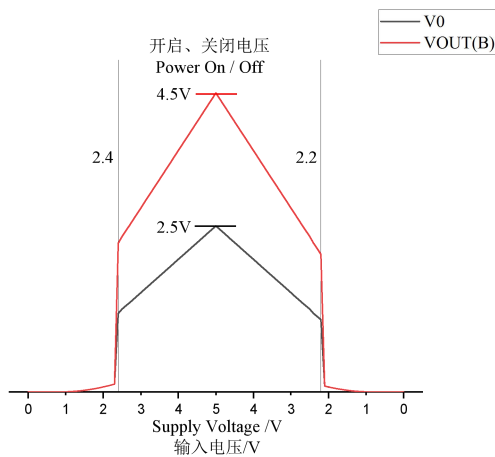

2. $\Delta (V_0 - V_{ref})$ 差分零点温漂 Quiescent Voltage of Differential Output drift through temperature (Sens=10mV/GS、B=200GS)

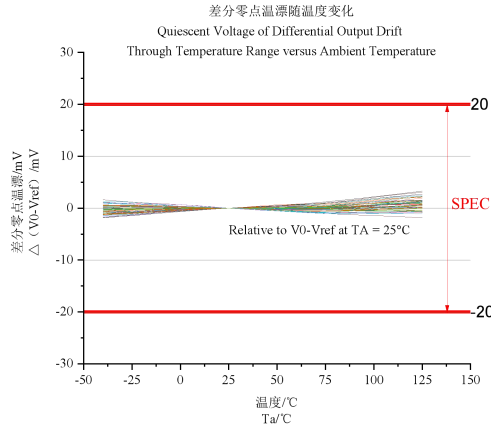

3. Sens_{TC} 灵敏度温漂 Sensitivity drift through temperature (Sens=10mV/GS、B=200GS)

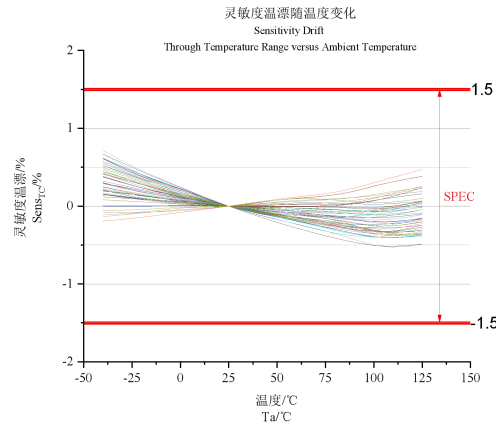

4. 输出电压-磁感应强度 Sensitivity as a function of magnetic flux density **B**.

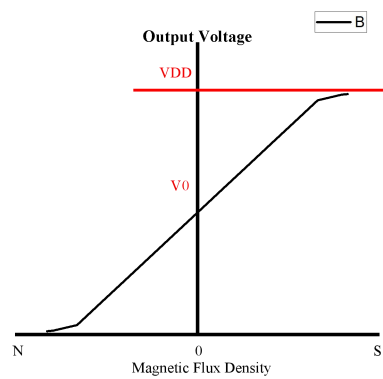

5. Tr 响应时间 Response Time (Sens=10mV/GS、B=50GS、CL=1nF)

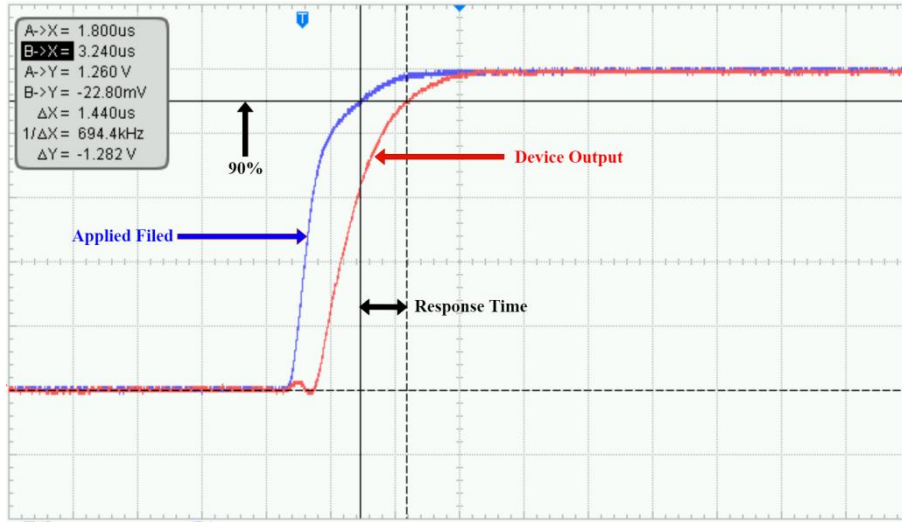

功能框图 Function Block Diagram

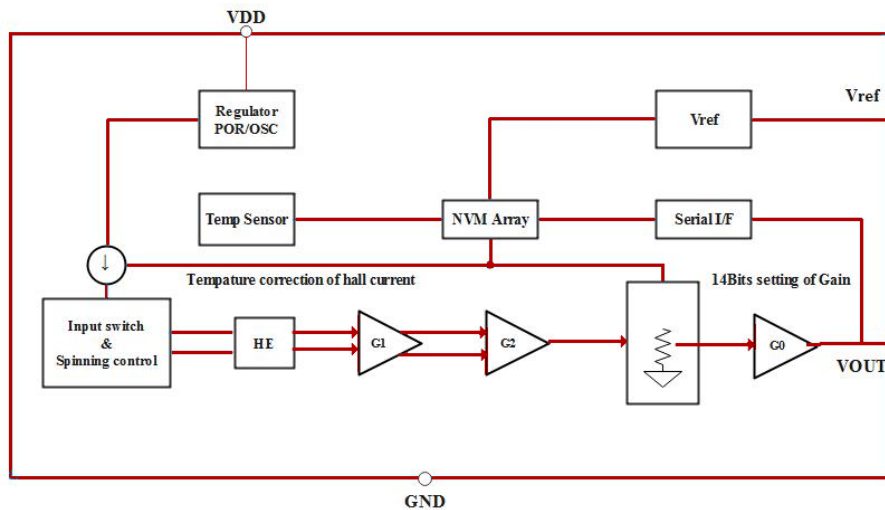

应用电路 Application Circuits

