

## HW-101A-4T InSb Hall Element

- Ultra High-sensitivity InSb Hall element
- Classic SOT Package
- Shipped in packet-tape reel (3000pcs per reel)

### Absolute Maximum Rating

Item	Symbol	Conditions	Limit	Unit
Operating Temperature Range	$T_{opr}$		-40 ~ +125	°C
Storage Temperature Range	$T_{STG}$		-55 ~ +150	°C
Maximum Input Current	$I_{cmax}$	$T_a = 25^\circ\text{C}$	20	mA
Maximum Input Voltage	$V_{cmax}$	$T_a = 25^\circ\text{C}$	2	V

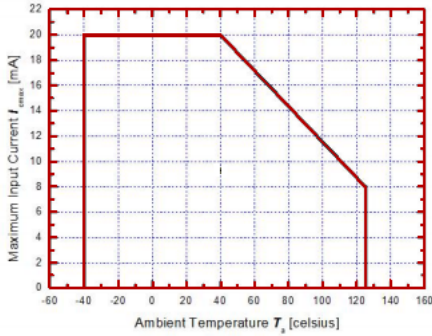

Figure 1. 1 Maximum input current  $I_{cmax}$

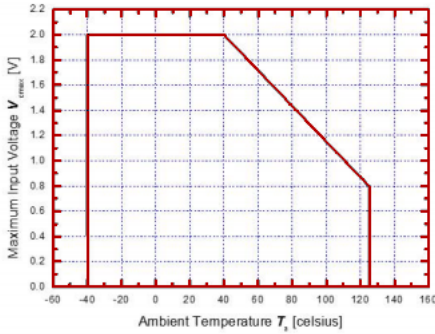
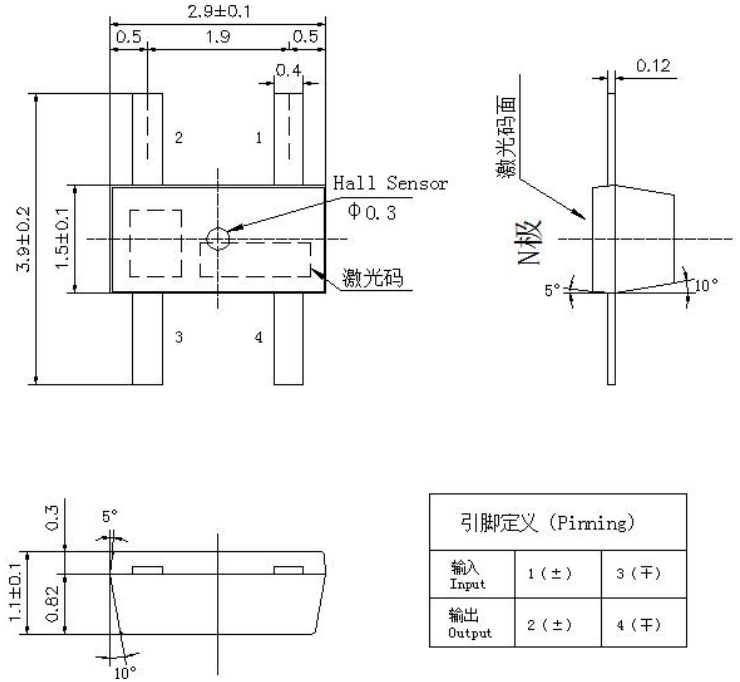

Figure 1. 2 Maximum input Voltage  $V_{cmax}$

### Dimensional Drawing (Unit: mm)



### Electrical Characteristics (RT=25°C)

Table 1. Electrical Characteristics of HW-101A-4T

Item	Symbol	Test Condi.	Min.	Typ.	Max.	Unit
Hall Voltage	$V_H$	$B = 50\text{mT}$ , $V_C = 1\text{V}$ $T_a = \text{RT}$	168		516	mV
Input Resistance	$R_{in}$	$B = 0\text{mT}$ , $I_C = 0.1\text{mA}$ $T_a = \text{RT}$	240		550	$\Omega$
Output Resistance	$R_{out}$	$B = 0\text{mT}$ , $I_C = 0.1\text{mA}$ $T_a = \text{RT}$	240		550	$\Omega$
Offset Voltage	$V_{os}$	$B = 0\text{mT}$ , $V_C = 1\text{V}$ $T_a = \text{RT}$	-5		+5	mV
Temp. Coeffi. of $V_H$	$\alpha V_H$	$B = 50\text{mT}$ , $I_C = 5\text{mA}$ , $T_a = 0^\circ\text{C} \sim 40^\circ\text{C}$		-1.8		%/°C
Temp. Coeffi. of $R_{in}$	$\alpha R_{in}$	$B = 0\text{mT}$ , $I_C = 0.1\text{mA}$ , $T_a = 0^\circ\text{C} \sim 40^\circ\text{C}$		-1.8		%/°C
Dielectric strength		100V D.C	1.0			M $\Omega$

Note:

$$1. \quad V_H = V_{H-M} - V_{os}$$

In which  $V_{H-M}$  is the Output Hall Voltage,  $V_H$  is the Hall Voltage and  $V_{os}$  is the offset voltage under the identical electrical stimuli.

$$2. \quad \alpha V_H = \frac{1}{V_H(T_1)} \times \frac{V_H(T_3) - V_H(T_2)}{(T_3 - T_2)} \times 100$$

$$3. \quad \alpha R_{in} = \frac{1}{R_{in}(T_1)} \times \frac{R_{in}(T_3) - R_{in}(T_2)}{(T_3 - T_2)} \times 100 \quad T_1 = 20^\circ\text{C}, T_2 = 0^\circ\text{C}, T_3 = 40^\circ\text{C}$$

### Classification of Output Hall Voltage ( $V_H$ )

**Table 2.** Classification of Hall Voltage

Rank	$V_H$ [mV]	Conditions
C	168 ~ 204	B=50mT, $V_C=1V$
D	196 ~ 236	
E	228 ~ 274	
F	266 ~ 320	
G	310 ~ 370	
H	360 ~ 415	
I	405 ~ 465	
J	454 ~ 516	

### Characteristic Curves

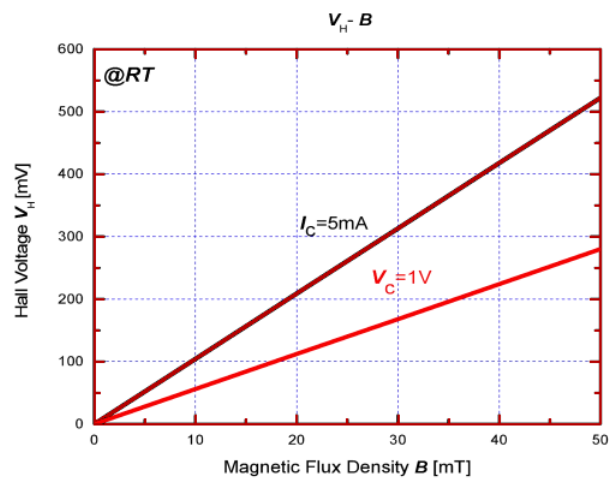
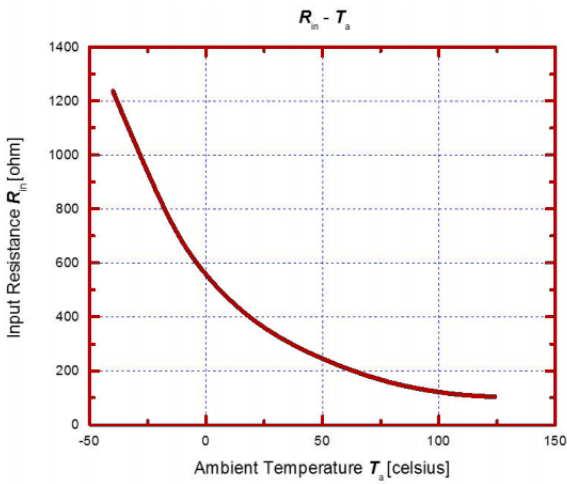

**Figure 2.** Input resistance  $R_{in}$  as a function of ambient temperature  $T_a$ .

**Figure 3.** Hall voltage  $V_H$  as a function of magnetic flux density  $B$ .

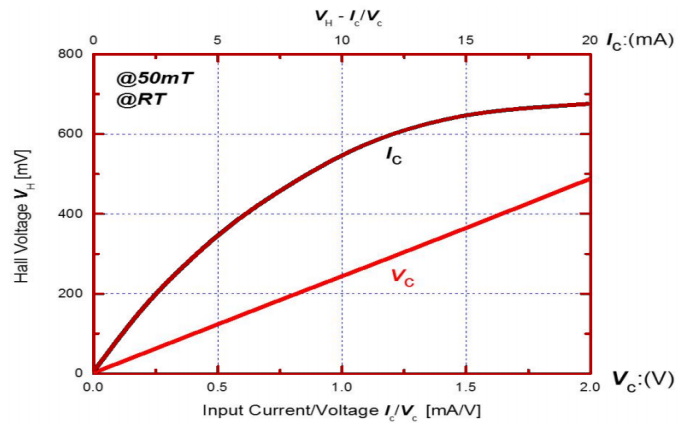
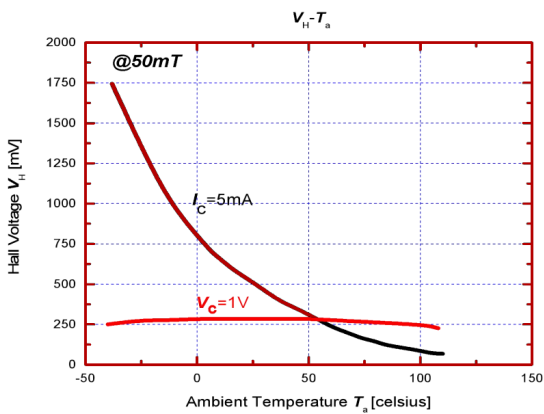

**Figure 4.** Hall voltage  $V_H$  as a function of ambient temperature  $T_a$ .

**Figure 5.** Hall voltage  $V_H$  as a function of electrical stimuli  $I_C/V_C$ .

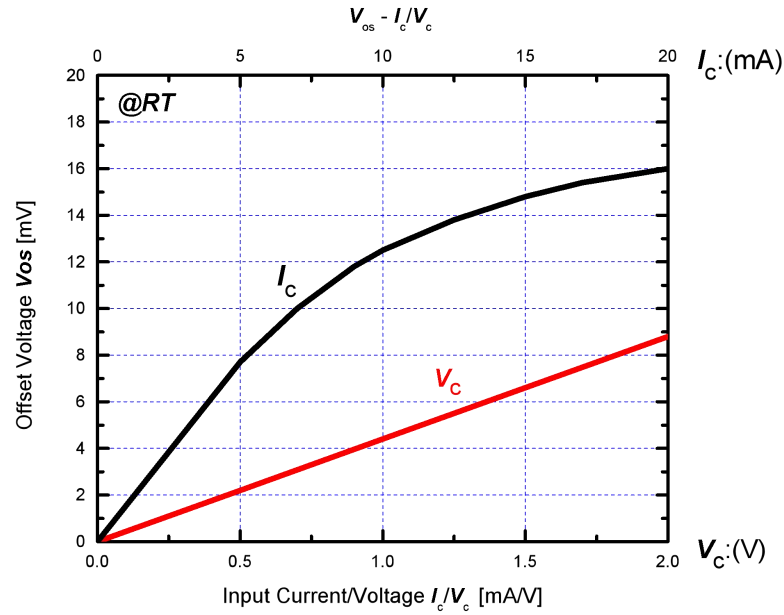

Figure 6. Offset voltage  $V_{os}$  as a function of electrical stimuli  $I_c/V_c$ .

## Reliability Test Terms

Table 2. Reliability Test Terms, Conditions and Duration.

No.	Terms	Conditions	Duration
1	High Temperature Storage (HTS)	【JEITA EIAJ ED-4701】 $T_a = 150 (0 \sim +10) \text{ }^\circ\text{C}$	1000 hrs
2	Heat Cycle (HC)	【JEITA EIAJ ED-4701】 $T_a = -55 \sim 150 \text{ }^\circ\text{C}$ high temp. - normal temp. - low temp. 30 min - 5 min - 30 min	30 cycles
3	Temp. Humidity Storage (THS)	【JEITA EIAJ ED-4701】 $T_a = 85 \pm 3 \text{ }^\circ\text{C}$ , $R_h = 85 \pm 5 \%$	1000 hrs
4	Reflow Soldering (RS)	【JEITA EIAJ ED-4701】 $260 \pm 5 \text{ }^\circ\text{C}$	10 sec
5	High Temp. Operating (HTO)	$T_a = 125 \text{ }^\circ\text{C}$ , $V_c = 1\text{V}$	1000 hrs

Criteria:

- Variation of Hall Voltage  $V_H$  and input/output resistances  $R_{in/out}$  are less than 20%.
- Variation of offset voltage  $V_{os}$  is less than  $\pm 16\text{mV}$ .
- Other parameters in Table 1. are still within their ranges stated in Table 1.

## Soldering Conditions

---

The following conditions should be preserved. Solder ability should be checked by yourself, because it is depend on solder paste material and other parameters.

### Material of solder flux

---

- Use the resin based flux and refrain from using organic or inorganic acid based and water-soluble one.

### Cleansing of solder flux conditions

---

- Use Ethanol or Isopropyl alcohol as cleansing material.
- Process temperature should be 50 °C or less.
- Duration should be 5 minutes or less.

### Hand soldering conditions

---

- Apart from the mold resin more than 1mm.
- Solder at temperature 300 °C for less than 5s.

### Wave soldering conditions

---

- Temperature in Pre-heating zone should be lower than 150°C.
- Temperature in Soldering zone should be lower than 270°C.

## Precautions for ESD

---

This product is the device that is sensitive to ESD (Electrostatic Discharge). Handling Hall Elements with the ESD-Caution mark under the environment in which

- Static electrical charge is unlikely to arise (Ex: Relative Humidity over 40%RH).
- Wearing the anti-static suit and wristband when handling the devices.
- Implementing measures against ESD as for containers that directly touch the devices.

## Precautions for Storage

---

- Products should be stored at an appropriate temperature and humidity (5° C to 35° C, 40%RH to 60%RH) after the unsealing of the MBB. Keeping products away from chlorine and corrosive gas.
- **For storage longer than 2 years**  
Products are sealed in MBB with a desiccant. It is recommended to store in nitrogen atmosphere with MBB sealed. Oxygen and H<sub>2</sub>O of atmosphere oxidizes leads of products and lead solder ability get worse.

## Precautions for Safety

---

- Do not alter the form of this product into a gas, powder or liquid through burning, crushing or chemical processing.
- Observe laws and company regulations when discarding this product.