

## FEATURES

- High Accuracy, Large Current
  - 0~200A Current sensor
  - Offset temperature drift:  $\pm 5\text{mV}$
  - Sensitivity total output error:  $\pm 1\%$
  - Typical sensitivity temperature drift:  $\pm 0.2\%$
  - Typical linearity error:  $\pm 0.2\%$
- High Bandwidth, Fast Response
  - Typical bandwidth: 250kHz
  - Typical response time: 1.5 $\mu\text{s}$
- High Anti-interference, High Isolation
  - The integrated magnetic core resists stray magnetic field interference.
  - Isolated voltage: 5000Vrms

## DESCRIPTION

The MTC921 series is an open-loop Hall current sensing chip that combines high accuracy, high bandwidth, high response, high linearity, and low temperature drift. MTC921 provides 0~200A large current measurement range. MTC921 can also do -40 °C ~ 125 °C full temperature range of typical sensitivity temperature drift  $\pm 0.2\%$  of the performance indicators. It provides a new solution for the high accuracy and high performance current sensor area. MTC921 adapts to strong electromagnetic and high isolation current detection environment. In addition, MTC921 series products have passed CE, TUV and other certifications.



## PACKAGE

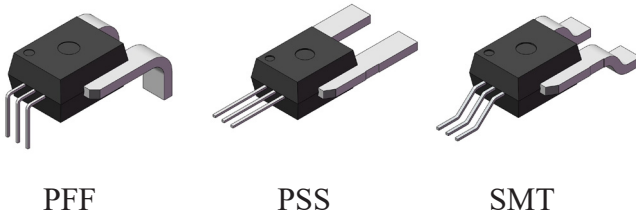

## TYPICAL APPLICATIONS

- Photovoltaic Inverter
- Industrial Inverter
- Commercial Air Conditioning
- Charging Station
- Welding Machine
- Balancing Car
- UPS

## TYPICAL APPLICATION CIRCUIT

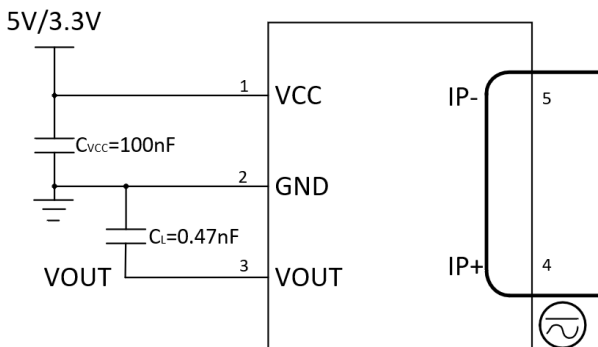

Figure 1. Typical Application Circuit Diagram

## THERMAL CURVE

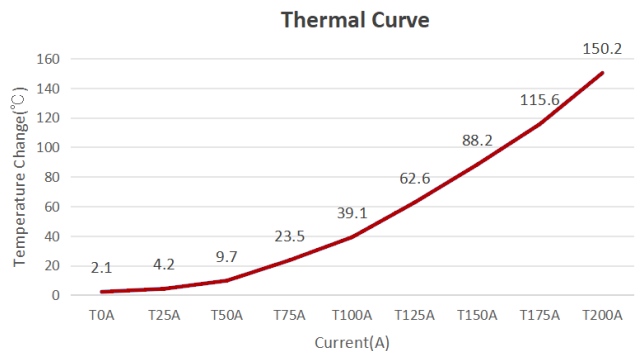

Figure 2. Thermal Curve



**SELECTION GUIDE**

Part Number	Output Mode	$I_{PR}(A)$	Sensitivity (mV/A)		Lead Form	Operating Temperature	Packing
			*=3	*=5			
MTC921-*KCB050U-PFF-T	Ratiometric Output Mode	50	52.8	80	PFF	-40°C ~ 125°C	34/40 pieces per tube
MTC921-*KCB050U-PSS-T					PSS		
MTC921-*KCB050U-SMT-T					SMT		
MTC921-*KCB050B-PFF-T		±50	26.4	40	PFF		
MTC921-*KCB050B-PSS-T					PSS		
MTC921-*KCB050B-SMT-T					SMT		
MTC921-*KCB100U-PFF-T		100	26.4	40	PFF		
MTC921-*CB100U-PSS-T					PSS		
MTC921-*KCB100U-SMT-T					SMT		
MTC921-*KCB100B-PFF-T		±100	13.2	20	PFF		
MTC921-*KCB100B-PSS-T					PSS		
MTC921-*KCB100B-SMT-T					SMT		
MTC921-*KCB150U-PFF-T		150	17.6	26.66	PFF		
MTC921-*KCB150U-PSS-T					PSS		
MTC921-*KCB150U-SMT-T					SMT		
MTC921-*KCB150B-PFF-T		±150	8.8	13.33	PFF		
MTC921-*KCB150B-PSS-T					PSS		
MTC921-*KCB150B-SMT-T					SMT		
MTC921-*ECB200U-PFF-T		200	13.2	20	PFF	-40°C ~ 85°C	
MTC921-*ECB200U-PSS-T					PSS		
MTC921-*ECB200U-SMT-T	SMT						
MTC921-*ECB200B-PFF-T	±200		6.6	10	PFF		
MTC921-*ECB200B-PSS-T					PSS		
MTC921-*ECB200B-SMT-T					SMT		

Note: Changes in ambient temperature may affect the maximum operating current of the product. For specific information, please refer to the derating curve. If you have other range requirements, please contact our sales. New range will be added without notice.

**PART NUMBER SPECIFICATION**

MTC921 - 5 E CB 200 B - PFF- T

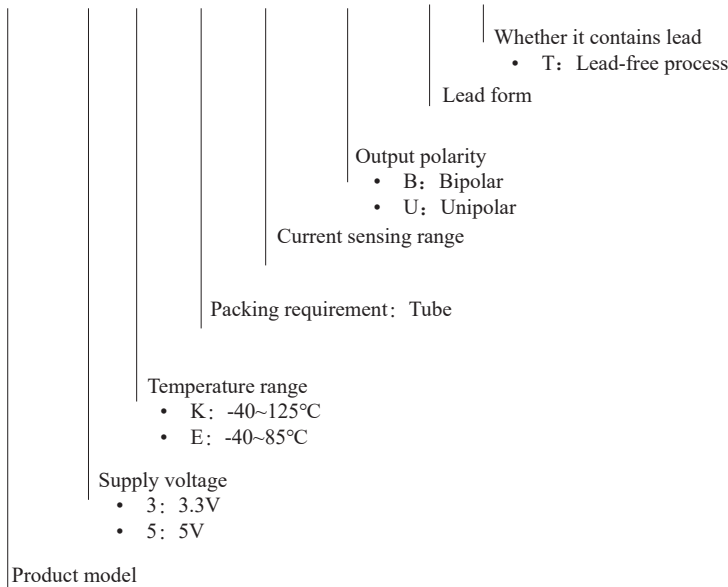

### 1. ABSOLUTE MAXIMUM RATINGS

Characteristic	Symbol	Unit	Min.	Typ.	Max.
Supply Voltage	$V_{CC}$	V	-0.3	/	6.5
Output Current	$I_{OUTmax}$	mA	-45	/	45
Proportional output	$V_{OUTmax}$	V	0.1	/	$V_{CC}-0.1$
Storage temperature	$T_S$	°C	-55	/	150
Operating Ambient Temperature	$T_A$	°C	-40	/	125
Maximum Junction Temperature	$T_{Jmax}$	°C	/	/	165

Note: Operation outside the absolute maximum ratings may cause permanent device damage. Absolute maximum ratings do not imply functional operation of the device at these or any other conditions beyond those listed under recommended operating conditions. If used outside the recommended operating conditions but within the absolute maximum ratings, the device may not be fully functional, and this may affect device reliability, functionality, performance, and shorten the device lifetime.

### 2. ESD RATINGS

Characteristic	Symbol	Unit	Notes	Value
Human Body Model	$V_{HBM}$	kV	ESD between any two pins	±6
Charged Device Model	$V_{CDM}$	kV		±1

### 3. ISOLATION CHARACTERISTICS

Characteristic	Symbol	Unit	Notes	Value
Dielectric Surge Voltage	$V_{SURGE}$	V	Test method refers to IEC61000-4-5, 1.2µs/50µs waveform.	8000
Dielectric Strength Test Voltage	$V_{ISO}$	$V_{RMS}$	60s, 50Hz isolation withstand voltage parameters, according to UL62368-1, test 6kV/1s before delivery to verify the insulation performance, and verify the partial discharge is less than 5pc.	5000
Working Voltage for Basic Isolation	$V_{WVBI}$	$V_{PK}$ or $V_{CC}$	Maximum approved working voltage for basic (single) isolation according to UL 60950-1 (edition 2).	1800
		$V_{RMS}$		1272
Working Voltage for Reinforced Isolation	$V_{WVRI}$	$V_{PK}$ or $V_{CC}$	Maximum approved working voltage for reinforced isolation according to UL 60950-1 (edition 2).	900
		$V_{RMS}$		636

### 4. TYPICAL OVERCURRENT CAPABILITY

Characteristic	Symbol	Unit	Notes	Value
Maximum Current Test	$I_{POC}$	A	$T_A=25^{\circ}\text{C}$ , Current On 1s, off 99s, Apply 100 pulses	1200
			$T_A=85^{\circ}\text{C}$ , Current On 1s, off 99s, Apply 100 pulses	900
			$T_A=125^{\circ}\text{C}$ , Current On 1s, off 99s, Apply 100 pulses	600

**5. PINOUT DIAGRAM & FUNCTIONAL BLOCK DIAGRAM**

Number	Name	Description
PIN1	VCC	Device power supply terminal pin
PIN2	GND	Device ground terminal pin
PIN3	VOUT	Analog output signal pin
PIN4	IP+	Current flows into the chip, positive direction
PIN5	IP-	Current flows out of the chip, negative direction

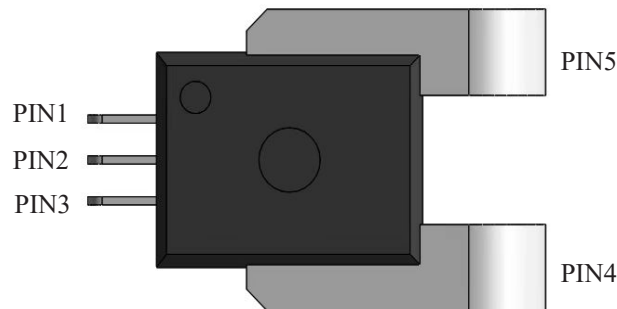
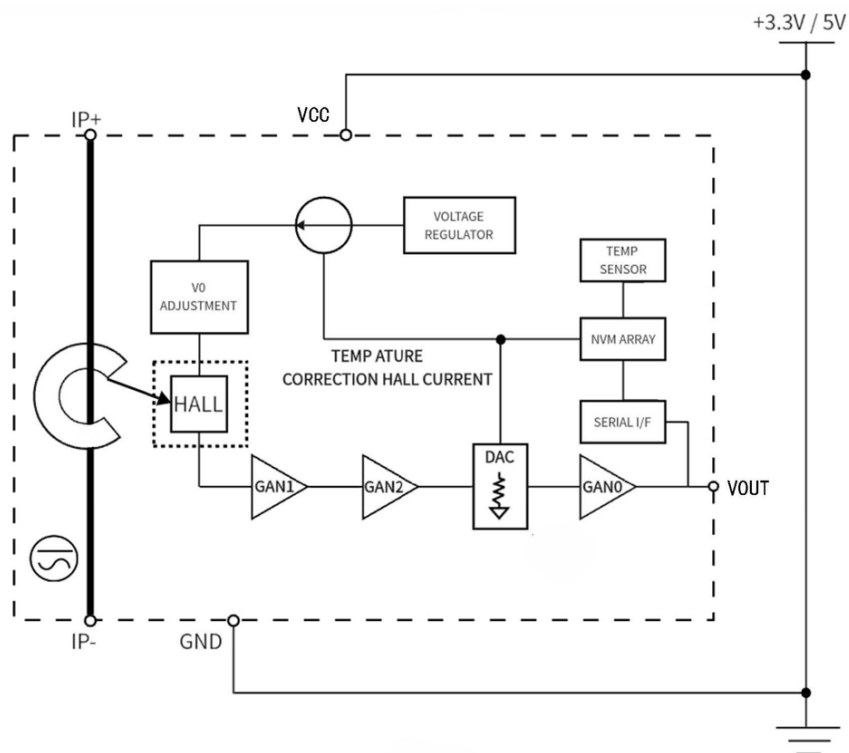

Figure 3. Pinout Diagram





**6. ELECTRICAL CHARACTERISTICS**

$T_A=25^{\circ}\text{C}$ ,  $V_{CC}=5\text{V}/3.3\text{V}$ ,  $C_L=0.47\text{nF}$ ,  $C_{VCC}=100\text{nF}$ (Unless otherwise noted)

Characteristic	Symbol	Unit	Test Conditions	Min.	Typ.	Max.
Rated Current	$I_{PN}$	A	MTC921-*KCB050U-XXX-T	0	/	50
			MTC921-*KCB050B-XXX-T	-50	/	50
			MTC921-*KCB100U-XXX-T	0	/	100
			MTC921-*KCB100B-XXX-T	-100	/	100
			MTC921-*KCB150U-XXX-T	0	/	150
			MTC921-*KCB150B-XXX-T	-150	/	150
			MTC921-*ECB200U-XXX-T	0	/	200
			MTC921-*ECB200B-XXX-T	-200	/	200
Supply Voltage	$V_{CC}$	V	*=3	3	3.3	3.6
			*=5	4.5	5	5.5
Supply Current <sup>Note1</sup>	$I_{CC}$	mA	*=3	6	6.5	12
			*=5	6	7.5	12
Primary Conductor Resistance <sup>Note1</sup>	$R_P$	m $\Omega$	/	/	0.1	/
Power-On Time <sup>Note2</sup>	$T_{PO}$	ms	Chip power-on ( $V_{CC}>3.0\text{V}$ ), $V_{OUT}$ stable time	/	1	/
Rise time	$T_R$	$\mu\text{s}$	/	/	1	/
Propagation Delay	$T_{PROP}$	$\mu\text{s}$	/	/	0.5	/
Response Time	$T_{RESPONSE}$	$\mu\text{s}$	/	/	1.5	/
Output Capacitive Load <sup>Note2</sup>	$C_L$	nF	$V_{OUT} - V_{GND}$	/	0.47	10
Output Resistive Load <sup>Note2</sup>	$R_L$	k $\Omega$	/	4.7	/	/
DC Output Resistance <sup>Note2</sup>	$R_{OUT}$	$\Omega$	/	/	1	/
Undervoltage-Lockout <sup>Note1</sup>	$V_{UVLOD}$	V	Undervoltage protection rising threshold	/	2.3	/
	$V_{UVLOE}$	V	Undervoltage protection drop threshold	/	2.1	/
Undervoltage-Lockout <sup>Note1</sup>	$T_{UVLOD}$	$\mu\text{s}$	Undervoltage protection rise time	/	500	/
	$T_{UVLOE}$	$\mu\text{s}$	Undervoltage protection drop time	/	50	/
Output Current Capability	$I_{SINK}$	mA	Sink current of output Pin	/	50	/
	$I_{SOURCE}$	mA	Source current of output Pin	/	55	/
Output Voltage Range	$V_S$	V	$R_L=10\text{k}\Omega$ to $V_{CC}$ or $GND$	0.1	/	$V_{CC}-0.1$
Internal Bandwidth	$BW_I$	kHz	200A range, small signal measurement	/	250	/
Sensitivity Symmetry Error	$E_{SYM}$	%	/	-0.1	$\pm 0.01$	0.1
Ratiometric Output Sensitivity Error <sup>Note1</sup>	$S_{ERR}$	%	$V_{CC}=3.15\sim 3.45\text{V}$	-0.5	0	0.5
			$V_{CC}=4.75\sim 5.25\text{V}$	-0.5	0	0.5
Nonlinearity <sup>Note1</sup>	$E_{LIN}$	%	$\leq 100\text{A}$	-0.1	0.03	0.1
			$\leq 200\text{A}$	-0.2	0.05	0.2
Sensitivity Temperature Drift <sup>Note1</sup>	$dS_{ERR}$	%	$T_A=85^{\circ}\text{C} \sim 125^{\circ}\text{C}$	-1.0	$\pm 0.2$	1.0
			$T_A=25^{\circ}\text{C} \sim 85^{\circ}\text{C}$	-0.8	$\pm 0.2$	0.8
			$T_A=-40^{\circ}\text{C} \sim 25^{\circ}\text{C}$	-1.0	$\pm 0.2$	1.0
Offset Temperature Drift <sup>Note1</sup>	$V_{IOUT(OTC)}$	mV	$T_A=25^{\circ}\text{C} \sim 125^{\circ}\text{C}$	-5	/	5
			$T_A=-40^{\circ}\text{C} \sim 25^{\circ}\text{C}$	-5	/	5

Note1: These parameters are obtained from laboratory testing with 3 $\sigma$  data.

Note2: These parameters are guaranteed by design.



## MTC921-\*KCB050U-XXX-T/MTC921-\*KCB050B-XXX-T PERFORMANCE CHARACTERISTICS

$T_A=25^{\circ}\text{C}$ ,  $V_{CC}=5\text{V}/3.3\text{V}$ ,  $C_L=0.47\text{nF}$ ,  $C_{VCC}=100\text{nF}$ (Unless otherwise noted)

Characteristic	Symbol	Unit	Test Conditions	Min.	Typ. <sup>Note1</sup>	Max.
<b>NOMINAL PERFORMANCE</b>						
Sensitivity ( $V_{CC}=3.3\text{V}$ )	$Sens$	mV/A	$I_{PRmin} < I_{PR} < I_{PRmax}$ MTC921-3KCB050U-XXX-T	/	$V_{CC} * 52.8$ /3.3	/
			$I_{PRmin} < I_{PR} < I_{PRmax}$ MTC921-3KCB050B-XXX-T	/	$V_{CC} * 26.4$ /3.3	/
Sensitivity ( $V_{CC}=5\text{V}$ )	$Sens$	mV/A	$I_{PRmin} < I_{PR} < I_{PRmax}$ MTC921-5KCB050U-XXX-T	/	$V_{CC} * 80$ /5	/
			$I_{PRmin} < I_{PR} < I_{PRmax}$ MTC921-5KCB050B-XXX-T	/	$V_{CC} * 40$ /5	/
Zero Current Output Voltage	$V_{IOUT(Q)}$	V	Unipolar, $I_{PR}=0\text{A}$	/	$V_{CC} * 0.1$	/
			Bipolar, $I_{PR}=0\text{A}$	/	$V_{CC} * 0.5$	/
<b>ACCURACY PERFORMANCE</b>						
Noise	$V_N$	mVrms	/	/	7	/
Magnetic Offset Error	$I_{ERROM}$	mV	$I_P=0\text{A}$ , $I_{PRmax}$	/	0.4	/
		mA	$I_P=0\text{A}$ , $I_{PRmax}$	/	10	/
Total Output Error	$E_{TOT}$	%	$I_P=I_{PRmax}$ , $T_A=-40^{\circ}\text{C} \sim 125^{\circ}\text{C}$	-1	$\pm 0.2$	1
<b>TOTAL OUTPUT ERROR COMPONENTS: <math>E_{TOT} = (V_{IOUT} - V_{IOUT Ideal}) / (Sens_{Ideal} \times I_P) \times 100\%</math></b>						
Sensitivity Error	$E_{SENS}$	%	$I_P=I_{PRmax}$ , $T_A=25^{\circ}\text{C} \sim 125^{\circ}\text{C}$	-0.5	$\pm 0.2$	0.5
Offset Error	$V_{OE}$	mV	$I_P=0\text{A}$ , $T_A=25^{\circ}\text{C} \sim 125^{\circ}\text{C}$	-10	$\pm 0.2$	10
			$I_P=0\text{A}$ , $T_A=25^{\circ}\text{C}$	-5	$\pm 0.2$	5
			$I_P=0\text{A}$ , $T_A=-40^{\circ}\text{C} \sim 125^{\circ}\text{C}$	-10	$\pm 0.2$	10
<b>LIFETIME DRIFT CHARACTERISTICS</b>						
Sensitivity Error Lifetime Drift	$E_{SENS\_drift}$	%	After reliability test, $T_A=25^{\circ}\text{C}$	/	$\pm 0.5$	/
Total Output Error Lifetime Drift	$E_{TOT\_drift}$	%	After reliability test, $T_A=25^{\circ}\text{C}$	/	$\pm 0.5$	/

Note: These parameters are obtained from laboratory testing with 3 $\sigma$  data.

## MTC921-\*KCB0100U-XXX-T/MTC921-\*KCB100B-XXX-T PERFORMANCE CHARACTERISTIC

$T_A=25^{\circ}\text{C}$ ,  $V_{CC}=5\text{V}/3.3\text{V}$ ,  $C_L=0.47\text{nF}$ ,  $C_{VCC}=100\text{nF}$ (Unless otherwise noted)

Characteristic	Symbol	Unit	Test Conditions	Min.	Typ. <sup>Note1</sup>	Max.
<b>NOMINAL PERFORMANCE</b>						
Sensitivity ( $V_{CC}=3.3\text{V}$ )	$Sens$	mV/A	$I_{PRmin} < I_{PR} < I_{PRmax}$ MTC921-3KCB100U-XXX-T	/	$V_{CC} * 26.4$ /3.3	/
			$I_{PRmin} < I_{PR} < I_{PRmax}$ MTC921-3KCB100B-XXX-T	/	$V_{CC} * 13.2$ /3.3	/
Sensitivity ( $V_{CC}=5\text{V}$ )	$Sens$	mV/A	$I_{PRmin} < I_{PR} < I_{PRmax}$ MTC921-5KCB100U-XXX-T	/	$V_{CC} * 40$ /5	/
			$I_{PRmin} < I_{PR} < I_{PRmax}$ MTC921-5KCB100B-XXX-T	/	$V_{CC} * 20$ /5	/
Zero Current Output Voltage	$V_{IOUT(Q)}$	V	Unipolar, $I_{PR}=0\text{A}$	/	$V_{CC} * 0.1$	/
			Bipolar, $I_{PR}=0\text{A}$	/	$V_{CC} * 0.5$	/
<b>ACCURACY PERFORMANCE</b>						
Noise	$V_N$	mVrms	/	/	5	/
Magnetic Offset Error	$I_{ERROM}$	mV	$I_P=0\text{A}$ , $I_{PRmax}$	/	0.6	/
		mA	$I_P=0\text{A}$ , $I_{PRmax}$	/	30	/
Total Output Error	$E_{TOT}$	%	$I_P=I_{PRmax}$ , $T_A=-40^{\circ}\text{C} \sim 125^{\circ}\text{C}$	-1	$\pm 0.2$	1
<b>TOTAL OUTPUT ERROR COMPONENTS: <math>E_{TOT} = (V_{IOUT} - V_{IOUT Ideal}) / (Sens_{Ideal} \times I_P) \times 100\%</math></b>						
Sensitivity Error	$E_{SENS}$	%	$I_P=I_{PRmax}$ , $T_A=25^{\circ}\text{C} \sim 125^{\circ}\text{C}$	-0.5	$\pm 0.2$	0.5
Offset Error	$V_{OE}$	mV	$I_P=0\text{A}$ , $T_A=25^{\circ}\text{C} \sim 125^{\circ}\text{C}$	-10	$\pm 0.2$	10
			$I_P=0\text{A}$ , $T_A=25^{\circ}\text{C}$	-5	$\pm 0.2$	5
			$I_P=0\text{A}$ , $T_A=-40^{\circ}\text{C} \sim 125^{\circ}\text{C}$	-10	$\pm 0.2$	10
<b>LIFETIME DRIFT CHARACTERISTICS</b>						
Sensitivity Error Lifetime Drift	$E_{SENS\_drift}$	%	After reliability test, $T_A=25^{\circ}\text{C}$	/	$\pm 0.5$	/
Total Output Error Lifetime Drift	$E_{TOT\_drift}$	%	After reliability test, $T_A=25^{\circ}\text{C}$	/	$\pm 0.5$	/

Note: These parameters are obtained from laboratory testing with 3 $\sigma$  data.



**MTC921-\*KCB150U-XXX-T/MTC921-\*KCB150B-XXX-T PERFORMANCE CHARACTERISTIC**

$T_A=25^{\circ}\text{C}$ ,  $V_{CC}=5\text{V}/3.3\text{V}$ ,  $C_L=0.47\text{nF}$ ,  $C_{VCC}=100\text{nF}$ (Unless otherwise noted)

Characteristic	Symbol	Unit	Test Conditions	Min.	Typ. <sup>Note1</sup>	Max.
<b>NOMINAL PERFORMANCE</b>						
Sensitivity ( $V_{CC}=3.3\text{V}$ )	$Sens$	mV/A	$I_{PRmin} < I_{PR} < I_{PRmax}$ MTC921-3KCB150U-XXX-T	/	$V_{CC} * 17.6 / 5$	/
			$I_{PRmin} < I_{PR} < I_{PRmax}$ MTC921-3KCB150B-XXX-T	/	$V_{CC} * 8.8 / 5$	/
Sensitivity ( $V_{CC}=5\text{V}$ )	$Sens$	mV/A	$I_{PRmin} < I_{PR} < I_{PRmax}$ MTC921-5KCB150U-XXX-T	/	$V_{CC} * 26.66 / 5$	/
			$I_{PRmin} < I_{PR} < I_{PRmax}$ MTC921-5KCB150B-XXX-T	/	$V_{CC} * 13.33 / 5$	/
Zero Current Output Voltage	$V_{IOUT(Q)}$	V	Unipolar, $I_{PR}=0\text{A}$	/	$V_{CC} * 0.1$	/
			Bipolar, $I_{PR}=0\text{A}$	/	$V_{CC} * 0.5$	/
<b>ACCURACY PERFORMANCE</b>						
Noise	$V_N$	mVrms	/	/	4	/
Magnetic Offset Error	$I_{ERROM}$	mV	$I_P=0\text{A}$ , $I_{PRmax}$	/	0.8	/
		mA	$I_P=0\text{A}$ , $I_{PRmax}$	/	60	/
Total Output Error	$E_{TOT}$	%	$I_P=I_{PRmax}$ , $T_A=-40^{\circ}\text{C} \sim 125^{\circ}\text{C}$	-1	$\pm 0.2$	1
<b>TOTAL OUTPUT ERROR COMPONENTS: <math>E_{TOT} = (V_{IOUT} - V_{IOUT Ideal}) / (Sens_{Ideal} * I_P) * 100\%</math></b>						
Sensitivity Error	$E_{SENS}$	%	$I_P=I_{PRmax}$ , $T_A=25^{\circ}\text{C} \sim 125^{\circ}\text{C}$	-0.5	$\pm 0.2$	0.5
Offset Error	$V_{OE}$	mV	$I_P=0\text{A}$ , $T_A=25^{\circ}\text{C} \sim 125^{\circ}\text{C}$	-10	$\pm 0.2$	10
			$I_P=0\text{A}$ , $T_A=25^{\circ}\text{C}$	-5	$\pm 0.2$	5
			$I_P=0\text{A}$ , $T_A=-40^{\circ}\text{C} \sim 125^{\circ}\text{C}$	-10	$\pm 0.2$	10
<b>LIFETIME DRIFT CHARACTERISTICS</b>						
Sensitivity Error Lifetime Drift	$E_{SENS\_drift}$	%	After reliability test, $T_A=25^{\circ}\text{C}$	/	$\pm 0.5$	/
Total Output Error Lifetime Drift	$E_{TOT\_drift}$	%	After reliability test, $T_A=25^{\circ}\text{C}$	/	$\pm 0.5$	/

Note: These parameters are obtained from laboratory testing with 3 $\sigma$  data.

**MTC921-\*KCB200U-XXX-T/MTC921-\*KCB200B-XXX-T PERFORMANCE CHARACTERISTIC**

$T_A=25^{\circ}\text{C}$ ,  $V_{CC}=5\text{V}/3.3\text{V}$ ,  $C_L=0.47\text{nF}$ ,  $C_{VCC}=100\text{nF}$ (Unless otherwise noted)

Characteristic	Symbol	Unit	Test Conditions	Min.	Typ. <sup>Note1</sup>	Max.
<b>NOMINAL PERFORMANCE</b>						
Sensitivity ( $V_{CC}=3.3\text{V}$ )	$Sens$	mV/A	$I_{PRmin} < I_{PR} < I_{PRmax}$ MTC921-3ECB200U-XXX-T	/	$V_{CC} * 13.2 / 3.3$	/
			$I_{PRmin} < I_{PR} < I_{PRmax}$ MTC921-3ECB200B-XXX-T	/	$V_{CC} * 6.6 / 3.3$	/
Sensitivity ( $V_{CC}=5\text{V}$ )	$Sens$	mV/A	$I_{PRmin} < I_{PR} < I_{PRmax}$ MTC921-5ECB200U-XXX-T	/	$V_{CC} * 20 / 5$	/
			$I_{PRmin} < I_{PR} < I_{PRmax}$ MTC921-5ECB200B-XXX-T	/	$V_{CC} * 10 / 5$	/
Zero Current Output Voltage	$V_{IOUT(Q)}$	V	Unipolar, $I_{PR}=0\text{A}$	/	$V_{CC} * 0.1$	/
			Bipolar, $I_{PR}=0\text{A}$	/	$V_{CC} * 0.5$	/
<b>ACCURACY PERFORMANCE</b>						
Noise	$V_N$	mVrms	/	/	3	/
Magnetic Offset Error	$I_{ERROM}$	mV	$I_P=0\text{A}$ , $I_{PRmax}$	/	1	/
		mA	$I_P=0\text{A}$ , $I_{PRmax}$	/	100	/
Total Output Error	$E_{TOT}$	%	$I_P=I_{PRmax}$ , $T_A=-40^{\circ}\text{C} \sim 125^{\circ}\text{C}$	-1	$\pm 0.2$	1
<b>TOTAL OUTPUT ERROR COMPONENTS: <math>E_{TOT} = (V_{IOUT} - V_{IOUT Ideal}) / (Sens_{Ideal} * I_P) * 100\%</math></b>						
Sensitivity Error	$E_{SENS}$	%	$I_P=I_{PRmax}$ , $T_A=25^{\circ}\text{C} \sim 125^{\circ}\text{C}$	-0.5	$\pm 0.2$	0.5
Offset Error	$V_{OE}$	mV	$I_P=0\text{A}$ , $T_A=25^{\circ}\text{C} \sim 125^{\circ}\text{C}$	-10	$\pm 0.2$	10
			$I_P=0\text{A}$ , $T_A=25^{\circ}\text{C}$	-5	$\pm 0.2$	5
			$I_P=0\text{A}$ , $T_A=-40^{\circ}\text{C} \sim 125^{\circ}\text{C}$	-10	$\pm 0.2$	10
<b>LIFETIME DRIFT CHARACTERISTICS</b>						
Sensitivity Error Lifetime Drift	$E_{SENS\_drift}$	%	After reliability test, $T_A=25^{\circ}\text{C}$	/	$\pm 0.5$	/
Total Output Error Lifetime Drift	$E_{TOT\_drift}$	%	After reliability test, $T_A=25^{\circ}\text{C}$	/	$\pm 0.5$	/

Note: These parameters are obtained from laboratory testing with 3 $\sigma$  data.

## 7. PARAMETERS DESCRIPTION

### 7.1 Sensitivity $Sens$

The change in sensor IC output in response to a 1A change through the primary conductor. The sensitivity is the product of the magnetic circuit sensitivity (G/A) ( $1G = 0.1 \text{ mT}$ ) and the linear IC amplifier gain (mV/G). The linear IC amplifier gain is programmed at the factory to optimize the sensitivity (mV/A) for the full-scale current of the device.

### 7.2 Sensitivity error $E_{SENS}$

Sensitivity error  $E_{SENS}$  refers to the percentage deviation between the actual measured sensitivity and the ideal sensitivity.

For example, when  $V_{CC} = 5V$ ,

$$E_{SENS} = (Sens_{Mens(5V)} - Sens_{Ideal(5V)}) / Sens_{Ideal(5V)} \times 100\%$$

### 7.3 The sensitivity temperature drift of $dS_{ERR}$

Over the entire operating temperature range is defined as:

$$dS_{ERR} = (Sens_{(TA)} - Sens_{(25^\circ C)}) / Sens_{(25^\circ C)} \times 100\%$$

### 7.4 Saturation output voltage $V_{OUT-SAT(H/L)}$

$V_{OUT-SAT(H)}$  is the maximum output of the chip under the positive current.

$V_{OUT-SAT(L)}$  is the maximum output of the chip under negative current.

### 7.5 Zero current output voltage $V_{IOUT(Q)}$

$I_p = 0$ , Output voltage of the sensor  $V_{IOUT(Q)}$ .

For bipolar devices, the output voltage  $V_{IOUT(Q)} = V_{CC} \times 0.5$ ,

For unipolar devices, the output voltage  $V_{IOUT(Q)} = V_{CC} \times 0.1$ .

Variation in  $V_{IOUT(Q)}$  can be attributed to the resolution of the linear IC quiescent voltage trim and thermal drift.

### 7.6 Offset voltage $V_{OE}$

Used to measure the influence of external non-magnetic factors. Under zero-current conditions, in ratiometric output mode, it is the difference between the actual output voltage and the theoretical output voltage.

### 7.7 Offset temperature drift $V_{IOUT(Q)TC}$

Due to internal circuit tolerance and heat dissipation, static output voltage due to internal circuit tolerance and heat dissipation  $V_{OUT(Q)}$  differential static output voltage  $V_{OE}$ . May shift with operating temperature  $V_{OUT(Q)TC}$ .

$$V_{IOUT(Q)TC} = V_{OUT(Q)(TA)} - V_{OUT(25^\circ C)}$$

### 7.8 Noise $V_N$

Noise is the macroscopic sum of thermal noise and shot noise inside the current sensor.

Dividing the noise (mV) by the sensitivity (mV/A) gives the smallest current that the device can resolve.

### 7.9 Symmetry $E_{SYM}$

Definition: The relationship between the actual output voltage  $V_{IOUT(Q)}$  and the forward half-range  $V_{IOUT-POSHALF}$  and reverse half-range  $V_{IOUT-NEGHALF}$  outputs.

The formula is defined as follows:

$$E_{SYM} = (1 - (V_{IOUT-POSHALF} - V_{IOUT(Q)}) / (V_{IOUT(Q)} - V_{IOUT-NEGHALF})) \times 100\%$$

### 7.10 Nonlinearity $E_{LIN}$

The design output of the device varies linearly with the measured current.

Ideally, under the same supply voltage and ambient temperature conditions, the output sensitivity of the device is the same for two different current sizes  $I_1$  (half scale current) and  $I_2$  (full scale current).

In practical application, there is a difference in sensitivity for the measurement of two different current sizes  $I_1$  and  $I_2$ , and nonlinear sensitivity error  $E_{LIN}$  describes the difference digitally.

In the chip, positive current nonlinearity  $E_{LINPOS}$  and negative current nonlinearity  $E_{LINNEG}$  are defined as follows:

$I_{POSx}$ ,  $I_{NEGx}$  is positive current and negative current

$$I_{POS2} = 2 \times I_{POS1}$$

$$I_{NEG2} = 2 \times I_{NEG1}$$

$$Sens_{Ix} = (V_{IOUT(Ix)} - V_{IOUT(Q)}) / Ix$$

$$E_{LINPOS} = (1 - (Sens_{IPOS2} / Sens_{IPOS1})) \times 100\%$$

$$E_{LINNEG} = (1 - (Sens_{INEG2} / Sens_{INEG1})) \times 100\%$$

Due to the hysteresis effect of the internal magnetic core, magnetic saturation exists at high currents. Therefore, the nonlinear error increases when the measured current exceeds 200A. [Specific reference to the sensitivity error  $E_{SENS}$ ]

## 7. PARAMETER DESCRIPTION (CONTINUED)

### 7.11 Proportional output sensitivity error $S_{ERR}$

The proportional output sensitivity error  $S_{ERR}$  is defined based on the supply voltage  $V_{CC}$ :

$$S_{ERR} = (1 - (Sens_{V_{CC}} / Sens_{5V}) / (V_{CC} / 5V)) \times 100\%$$

$$S_{ERR} = (1 - (Sens_{V_{CC}} / Sens_{3.3V}) / (V_{CC} / 3.3V)) \times 100\%$$

Proportional output error of static voltage  $V_{0zero}$

Error between the ratio of  $V_{out1}$  and  $V_{out0}$  value at  $V_{CC}=5V$  and the theoretical ratio when  $V_{CC}$  varies from 4.5V to 5.5V, or at  $V_{CC}=3.3V$  and the theoretical ratio when  $V_{CC}$  varies from 3.0V to 3.6V.

$$V_{0zero} = (1 - (V_{out1} / V_{out0}) / (V_{CC} / 5V)) \times 100\%$$

$$V_{0zero} = (1 - (V_{out1} / V_{out0}) / (V_{CC} / 3.3V)) \times 100\%$$

### 7.12 Total output error $E_{TOT}$

The difference between the current measurement from the sensor IC and the actual current ( $I_p$ ), relative to the actual current. This is equivalent to the difference between the ideal output voltage and the actual output voltage, divided by the ideal sensitivity, relative to the current flowing through the primary conduction path:

$$E_{TOT} = (V_{IOUT} - V_{IOUTIdeal}) / (Sens_{Ideal} \times I_p) \times 100\%$$

At relatively large current,  $E_{TOT}$  is mainly sensitivity error, while at relatively small current,  $E_{TOT}$  is mainly zero current sensitivity error voltage  $V_{0E}$ . As  $I_p$  approaches zero,  $E_{TOT}$  approaches infinity due to the bias voltage.

$$V_{IOUTIdeal} = V_{IOUT(Q)} + (Sens_{Ideal} \times I_p)$$

### 7.13 Dynamic response characteristic

#### 7.13.1 Power-on time $T_{PO}$

When the supply is ramped to its operating voltage, the device requires a finite amount of time to power its internal components before responding to an input magnetic field. Power-On Time ( $T_{PO}$ ) is defined as the time interval between the power supply has reached its minimum specified operating voltage ( $V_{UVLOD}$ ) and the sensor output has settled within  $\pm 10\%$  of its steady-state value under an applied magnetic field.

#### 7.13.2 Rise time $T_r$

The time interval between the sensor output voltage reaches 10% of its full-scale value and it reaches 90% of its full-scale value.

#### 7.13.3 Propagation delay $T_{PROP}$

The time interval between the sensed primary current reaches 20% of its final value and the sensor output voltage reaches 20% of its full-scale value.

#### 7.13.4 Response Time $T_{RESPONSE}$

The time interval between the sensed primary current reaches 90% of its final value and the sensor output voltage reaches 90% of its full-scale value.

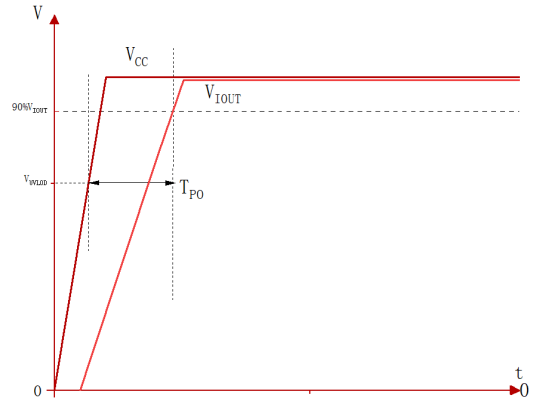

Figure 5. Power-on Time  $T_{PO}$

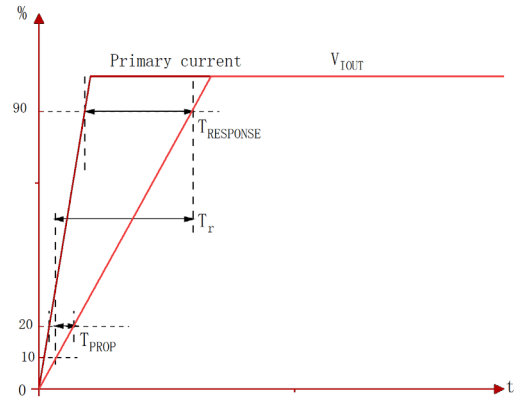

Figure 6. Dynamic Response Time Parameters

## 8. THERMAL EVALUATION

The product will naturally heat up during using, and the thermal curve performance of this device was measured in a windless environment at 25±3°C in Zhangjiagang application laboratory using a EVM.

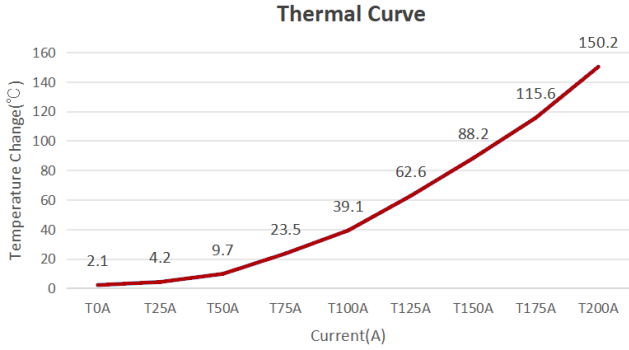
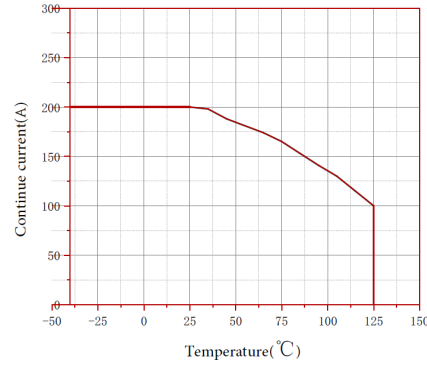

Figure 7. Thermal curve



Products above 200A are only used for transient current detection, if you need to work for a long time, please add additional heat dissipation.

Figure 8. Derating curve

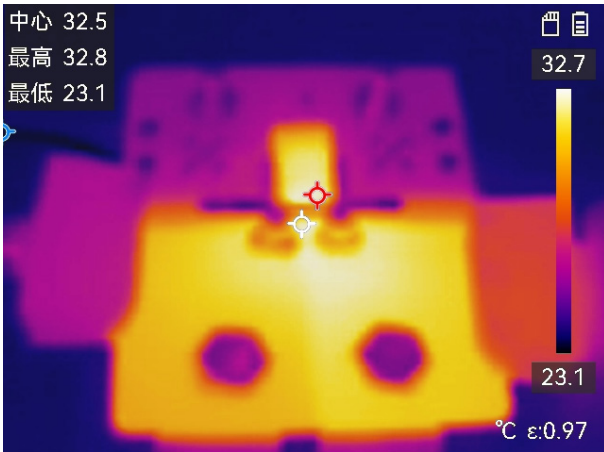

Figure 9. Thermal performance of 50A

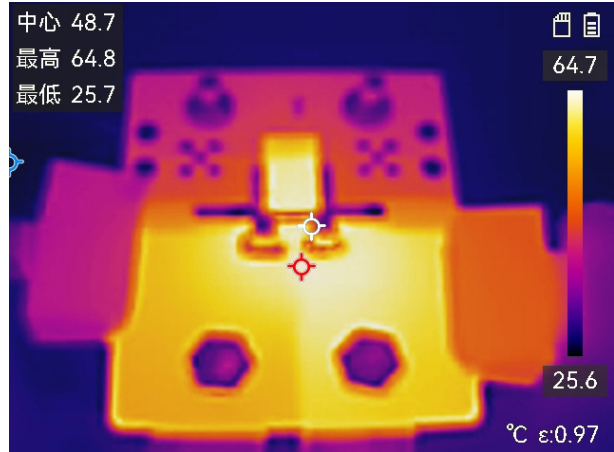

Figure 10. Thermal performance of 100A

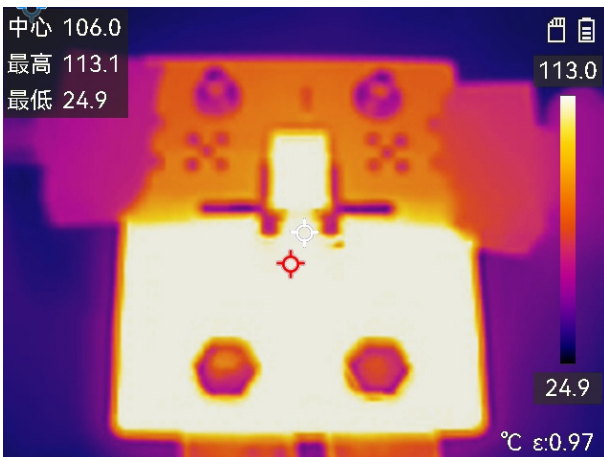

Figure 11. Thermal performance of 150A

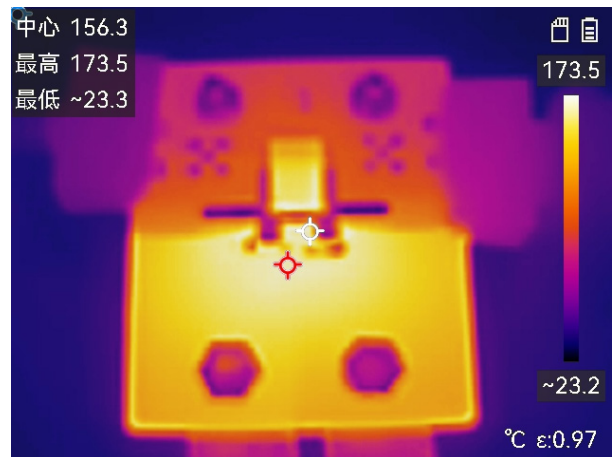

Figure 12. Thermal performance of 200A

## 9. LAYOUT GUIDELINES

Test information of the demo board

The IP heat dissipation copper thickness of the demo board is 4oz, the heat dissipation area is  $2 \times 986 \text{ (mm}^2\text{)}$ , the test wiring uses Kelvin sense to avoid the voltage drop caused by GND impedance, and capacitors should set to the chip pins as close as possible.  $C_L=0.47\text{nF}$ ,  $C_{VCC}=100\text{nF}$

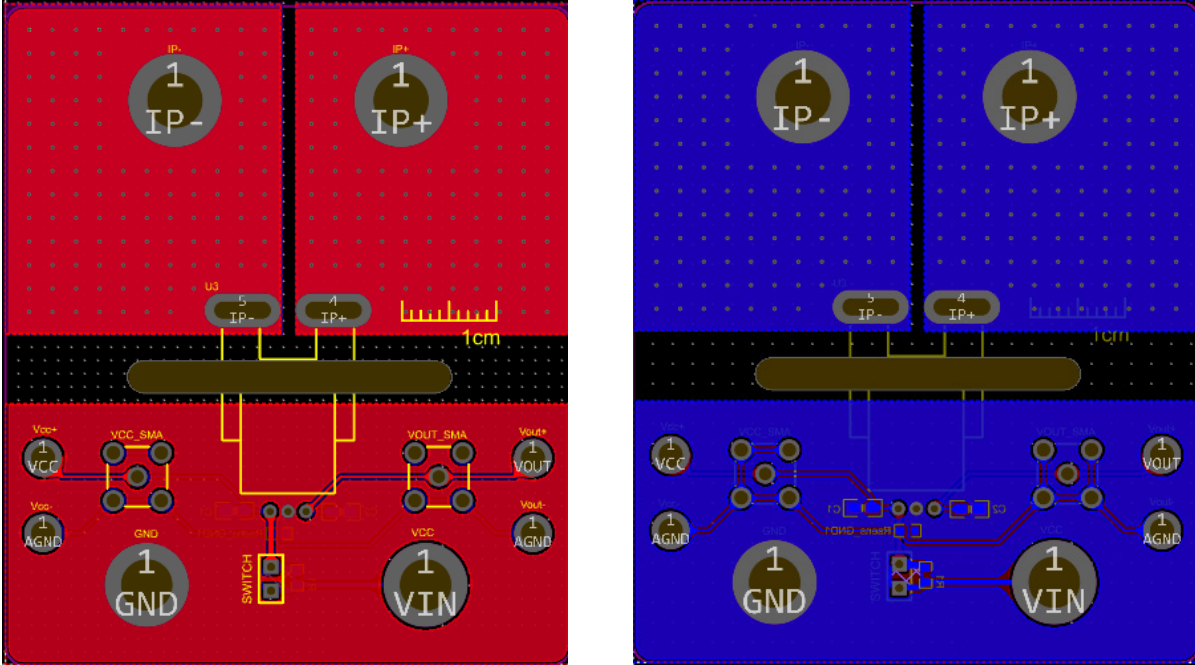
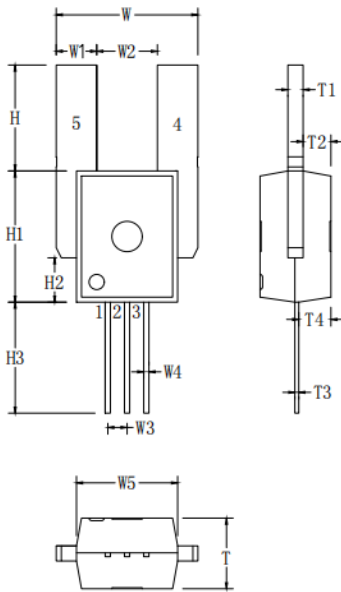

Figure 13. Demo board

## 10. PACKAGE OUTLINE



NUM	SIZE (mm)			NOTE
	MIN	NOM	MAX	
W	13.80	14.00	14.20	
W1	3.80	4.00	4.20	
W2	5.80	6.00	6.20	
W3	1.70	1.90	2.10	
W4	0.41	0.51	0.61	
W5	9.90	10.00	10.10	
H	10.00	10.50	11.00	
H1	12.90	13.00	13.10	
H2	4.30	4.40	4.50	
H3	10.50	11.00	11.50	
T	6.90	7.00	7.10	
T1	1.40	1.50	1.60	
T2	2.65	2.75	2.85	
T3	0.33	0.38	0.43	
T4	3.08	3.18	3.28	

Figure 15. 5PIN-PSS Package

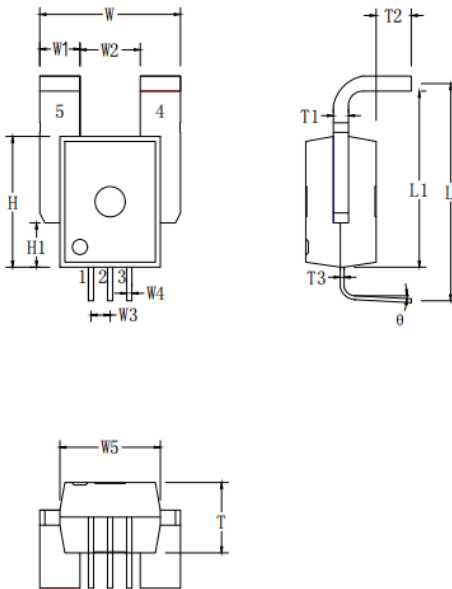

NUM	SIZE (mm)			NOTE
	MIN	NOM	MAX	
W	13.80	14.00	14.20	
W1	3.80	4.00	4.20	
W2	5.80	6.00	6.20	
W3	1.70	1.90	2.10	
W4	0.41	0.51	0.61	
W5	9.90	10.00	10.10	
T	6.90	7.00	7.10	
H	12.90	13.00	13.10	
H1	4.30	4.40	4.50	
T1	1.40	1.50	1.60	
T2	3.30	3.50	3.70	
T3	0.33	0.38	0.43	
L	20.40	21.40	22.40	
L1	17.30	17.50	17.70	
theta 1	0°	5°	10°	
theta 2	-1°	1°	3°	

Figure 16. 5PIN-PFF Package

Example Board Layout:

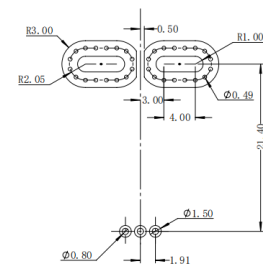

General linear tolerance:  $\pm 0.2\text{mm}$

Figure 17. Recommend pad size

10. PACKAGE OUTLINE(CONTINUED)

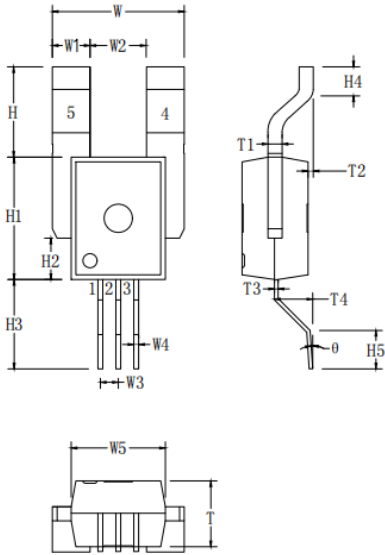

NUM	SIZE (mm)			NOTE
	MIN	NOM	MAX	
W	13.80	14.00	14.20	
W1	3.80	4.00	4.20	
W2	5.80	6.00	6.20	
W3	1.70	1.90	2.10	
W4	0.41	0.51	0.61	
W5	9.90	10.00	10.10	
H	9.10	9.60	10.10	
H1	12.90	13.00	13.10	
H2	4.30	4.40	4.50	
H3	9.00	9.50	10.00	
H4	1.90	2.40	2.90	
H5	3.30	3.80	4.30	
θ	0°	4°	8°	

NUM	SIZE (mm)			NOTE
	MIN	NOM	MAX	
T	6.90	7.00	7.10	
T1	1.40	1.50	1.60	
T2	0.00	0.50	1.00	
T3	0.33	0.38	0.43	
T4	3.20	3.70	4.20	

Figure 18. 5PIN-SMT Package

Example Board Layout:

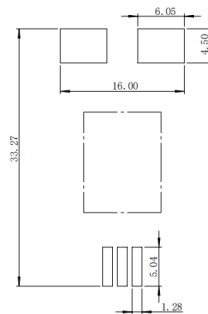

General linear tolerance: ±0.2mm

Figure 19. Recommend pad size

## 11. PACKING & STORAGE INFORMATION

### 11.1 Packing

Tube, 34/40 pieces per tube

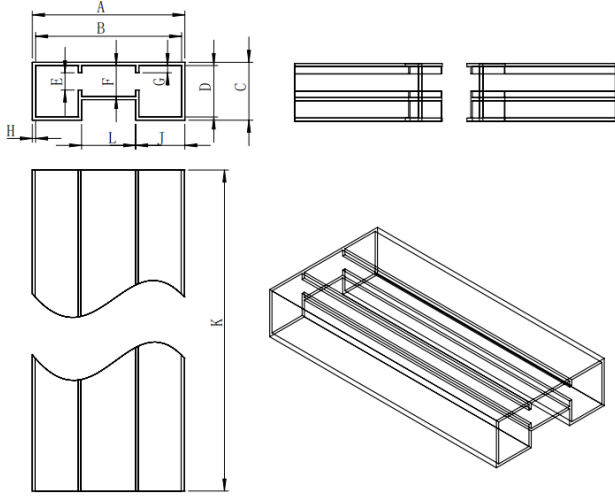

NUM	SIZE (mm)		
	MIN	NOM	MAX
A	37.80	38.00	38.20
B	36.20	36.40	36.60
C	13.80	14.00	14.20
D	12.20	12.40	12.60
E	4.10	4.30	4.50
F	7.50	7.70	7.90
G	1.60	1.80	2.00
H	0.60	0.80	1.00
L	13.50	13.70	13.90
J	11.95	12.15	12.35
K	524.00	525.00	526.00

Figure 20. 34 PCS packing

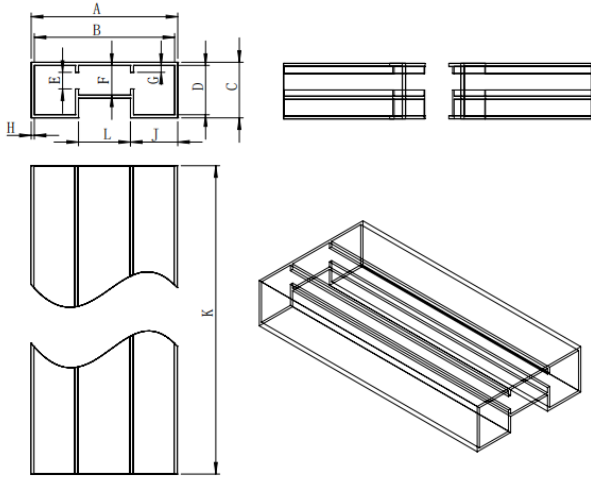

NUM	SIZE (mm)		
	MIN	NOM	MAX
A	37.80	38.00	38.20
B	36.20	36.40	36.60
C	13.80	14.00	14.20
D	12.20	12.40	12.60
E	4.10	4.30	4.50
F	7.50	7.70	7.90
G	1.60	1.80	2.00
H	0.60	0.80	1.00
L	13.50	13.70	13.90
J	11.95	12.15	12.35
K	589.00	590.00	591.00

Figure 21. 40 PCS packing

### 11.2 Storage information

11.2.1 The product should be stored at MSL3 standard.

## 12. SAFETY WARNING

The environmental requirements of this product are as follows:

12.1 ESD control should be done when touching the product.

12.2 The use of this product shall comply with the relevant provisions of local laws and regulations.