

Parameter	Symbol	Rating	Units
Load Voltage	V _L	600	V
Load Current	I _L	0.2	A
On Resistance	R _{on}	13	Ω
I/O Breakdown Voltage	V _{io}	3750	V _{rms}



SMD-6



DIP-6

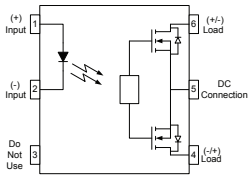

1. LED Anode
2. LED Cathode
4. Drain (MOS FET)
5. Source (MOS FET)
6. Drain (MOS FET)

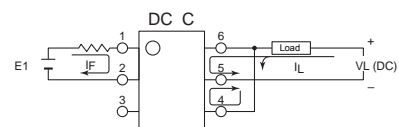
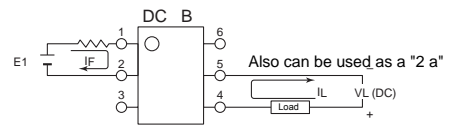
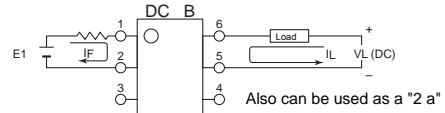
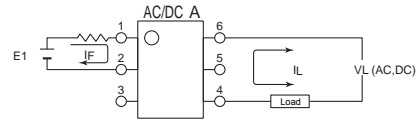

APSEMI PhotoRelays

APSEMI Photorelays are the most reliable, technically advanced logic-to-power interface devices. Their basic function is to take a low current signal from a microprocessor to control the switching of both AC and DC loads, while providing an isolation barrier between logic and power. While this function is common to all relays, Photorelays provide distinct advantages over their mechanical counterparts including:

- Long life (No limit on mechanical and electrical lifetime)
- Bounce-free switching
- Higher speed and high frequency switching
- Higher sensitivity (less power consumption)
- Immunity to EMI or RFI
- No have voltaic arc, bounce, and noise
- More resistant to vibration and impact
- AC or DC load switching
- Small package size

Applications

These advantages make APSEMI Photorelays the ideal choice for:

- Telecom/Datacom switching
- Multiplexers
- Meter reading systems
- Data acquisition
- Medical equipment
- Battery monitoring
- I/O Sub-Systems
- Robotics
- Aerospace
- Home/Safety security systems
- Process Control
- Energy Management
- Reed Relay EMR Replacement
- Programmable Controllers

TPYES

Category	Output Rating		Package	Part No.	Packing Quantity
	Load Voltage	Load Current			
AC/DC	600V	0.2A	DIP-6	APV256AE	50pcs /tube
			SMD-6	APV256AEH	1000pcs /reel

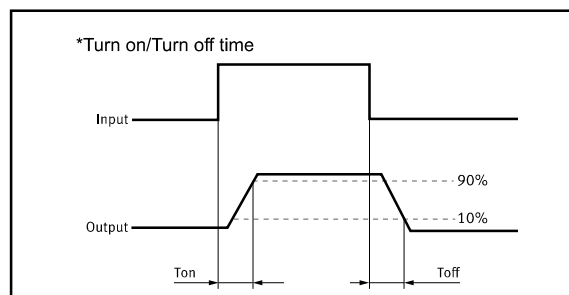

**RATING**

Absolute maximum ratings

Parameter	Symbol	Min.	Max.	Units	Note	
Storage Temperature	T_S	-55	125	°C		
Operating Temperature	T_A	-40	85	°C		
Junction Temperature	T_J		125	°C		
Lead Soldering Cycle	Temperature		260	°C		
	Time		10	sec		
Input Current	Average	I_F	25	mA		
	Surge		50	mA		
	Transient		1000	mA		
Reversed Input Voltage	V_R		5	V		
Input Power Dissipation	P_{IN}		40	mW		
Output Power Dissipation	Connection A	P_O	640	mW		
	Connection B		640	mW		
Average Output Current ($T_A=25^\circ\text{C}$, $T_C \leq 100^\circ\text{C}$)	Connection A	I_O	0.2	A		
	Connection B		0.4	A		
Output Voltage ($T_A=25^\circ\text{C}$)	Connection A	V_O	- 600	600	V	1
	Connection B		0	600	V	
Solder Reflow Temperature Profile	See Lead Free IR Profile					

Recommended operating conditions

Please use under recommended operating conditions to obtain expected characteristics.

Parameter	Symbol	Min.	Max.	Units	Note
Input Current (ON)	$I_{F(ON)}$	3	20	mA	
Input Voltage (OFF)	$V_{F(OFF)}$	0	0.8	V	
Operating Temperature	T_A	-40	+85	°C	



Electrical characteristics

Electrical Specifications (DC)

Over recommended operating $T_A = -40^{\circ}\text{C}$ to 85°C , $I_F = 5\text{mA}$ to 10mA , unless otherwise specified.

Parameter	Sym.	Min.	Typ.	Max.	Units	Conditions	Fig.	Note
Output Withstand Voltage	$ V_{O(OFF)} $	600	650		V	$V_F=0.8\text{V}, I_O=250\mu\text{A}, T_A=25^{\circ}\text{C}$		
		550			V	$V_F=0.8\text{V}, I_O=250\mu\text{A}$		
Output On-Resistance	Connection A	$R_{(ON)}$	13	16	Ω	$I_F=5\text{mA}, I_O=0.2\text{A},$ Pulse $\leq 30\text{ms}, T_A=25^{\circ}\text{C}$	3	-
	Connection B	$R_{(ON)}$	2.5	6	Ω	$I_F=5\text{mA}, I_O=0.4\text{A},$ Pulse $\leq 30\text{ms}, T_A=25^{\circ}\text{C}$	11	6
Output Leakage Current	$I_{O(OFF)}$		0.001	0.1	μA	$V_F=0.8\text{V}, V_O=600\text{V}, T_A=25^{\circ}\text{C}$	5	-
					1	μA	$V_F=0.8\text{V}, V_O=550\text{V}$	4
Output Off-Capacitance	$C_{(OFF)}$		500		pF	$V_F=0.8\text{V}, V_O=0\text{V}, f=1\text{MHz}$	6	-
Output Offset Voltage	$ V_{(OS)} $		1		μV	$I_F=5\text{mA}, I_O=0\text{mA}$		
Input Reverse Breakdown Voltage	V_R	5			V	$I_R=10\mu\text{A}$		
Input Forward Voltage	V_F	1.1	1.3	1.7	V	$I_F=5\text{mA}$	7,8	-

Switching Specifications (AC)

Over recommended operating $T_A = -40^{\circ}\text{C}$ to 85°C , $I_F = 5\text{mA}$ to 10mA , unless otherwise specified.

Parameter	Sym.	Min.	Typ.	Max.	Units	Conditions	Fig.	Note
Turn On Time	T_{ON}		0.7	2.5	ms	$I_F=5\text{mA}, I_O=0.4\text{A}, T_A=25^{\circ}\text{C}$	12,16	
				5.0	ms	$I_F=5\text{mA}, I_O=0.4\text{A}$	13,16	
			0.4	1.5	ms	$I_F=10\text{mA}, I_O=0.4\text{A}, T_A=25^{\circ}\text{C}$	12,16	
				3.0	ms	$I_F=10\text{mA}, I_O=0.4\text{A}$	13,16	
Turn Off Time	T_{OFF}		0.07	0.5	ms	$I_F=5\text{mA}, I_O=0.4\text{A}, T_A=25^{\circ}\text{C}$	14,16	
				1	ms	$I_F=5\text{mA}, I_O=0.4\text{A}$	15,16	
			0.06	0.2	ms	$I_F=10\text{mA}, I_O=0.4\text{A}, T_A=25^{\circ}\text{C}$	14,16	
				0.5	ms	$I_F=10\text{mA}, I_O=0.4\text{A}$	15,16	
Output Transient Rejection	dV_O/dt	1	7		kV/ μs	$\Delta V_O=600\text{V}, R_M \geq 1\text{M}\Omega,$ $C_M=1000\text{pF}, T_A=25^{\circ}\text{C}$	17	5
Input-Output Transient Rejection	dV_{I-O}/dt	1	20		kV/ μs	$V_{DD}=5\text{V}, \Delta V_{I-O}=1000\text{V},$ $R_L=1\text{k}\Omega, C_L=25\text{pF}, T_A=25^{\circ}\text{C}$	18	5



Engineering Data

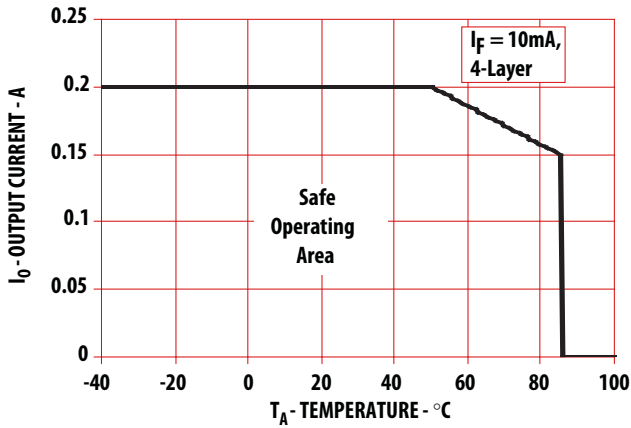

Figure 1. Maximum Output Current Rating vs Ambient Temperature (AC/DC Connection)

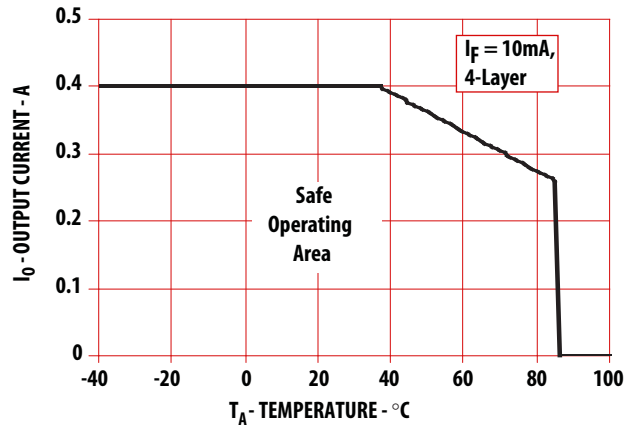

Figure 2. Maximum Output Current Rating vs Ambient Temperature (DC Connection)

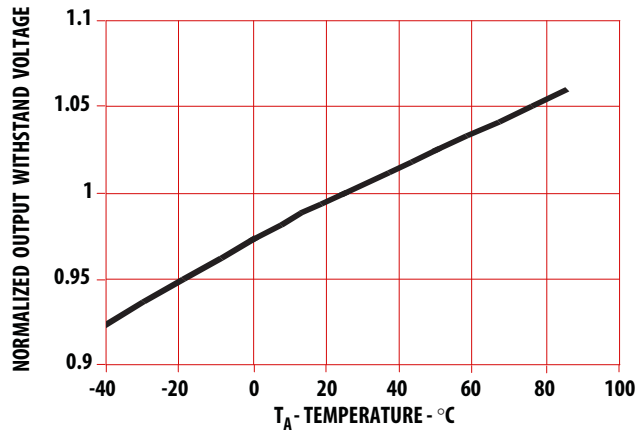

Figure 3. Normalized Typical Output Withstand Voltage vs Temperature

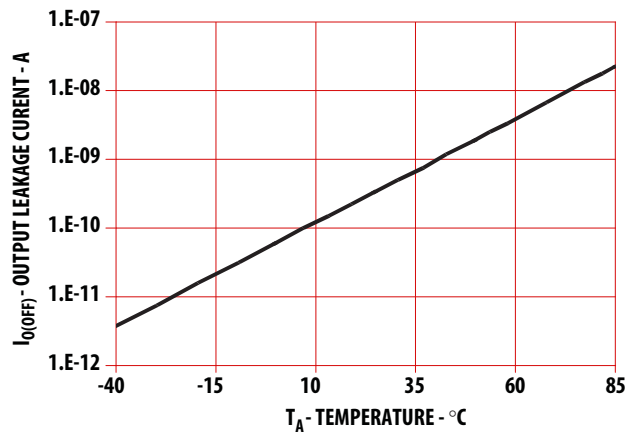

Figure 4. Typical Output Leakage Current vs Ambient Temperature

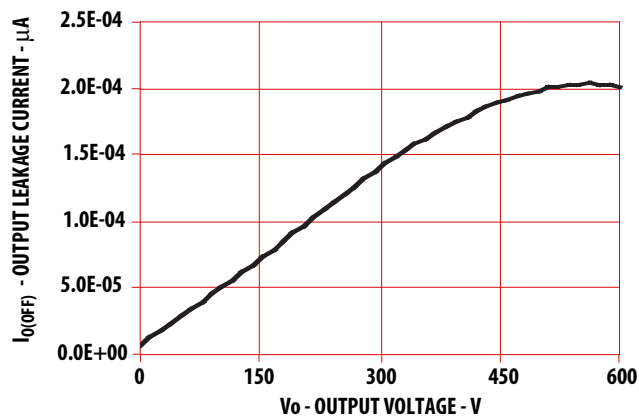

Figure 5. Typical Output Leakage Current vs Output Voltage

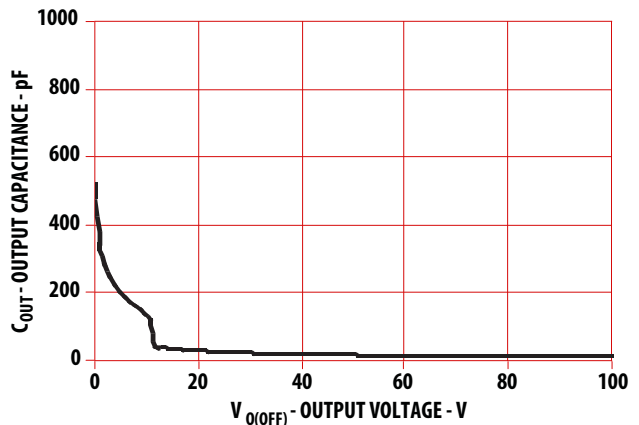

Figure 6. Typical Output Off-State Capacitance vs Output Voltage



Engineering Data

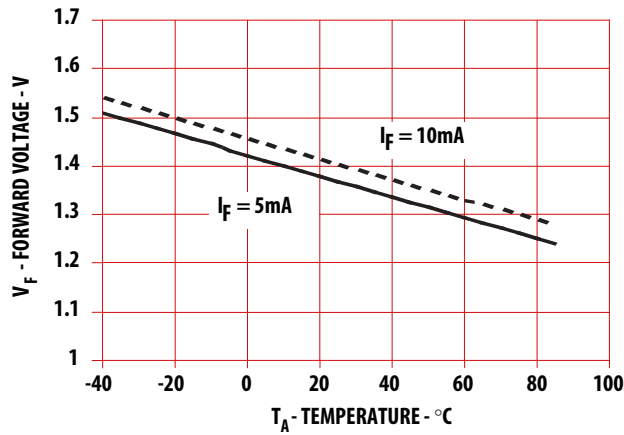

Figure 7. Typical Forward Voltage vs Ambient Temperature

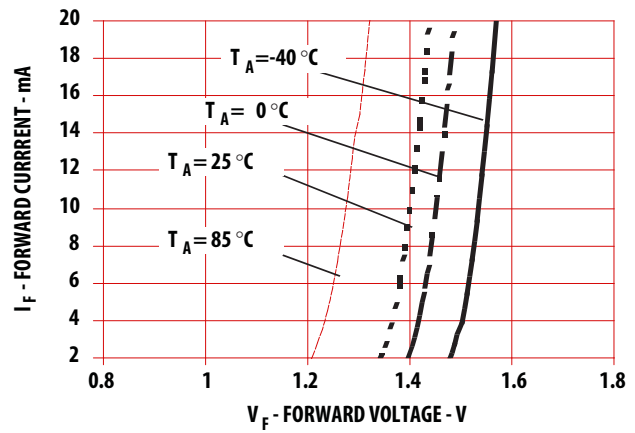

Figure 8. Typical Forward Current vs Forward Voltage

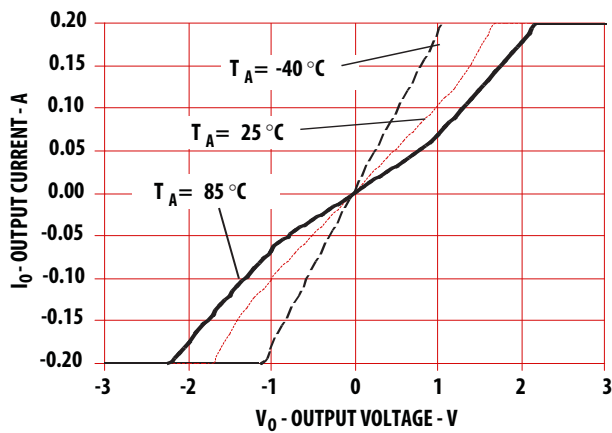

Figure 9. Typical Output Current vs Output Voltage

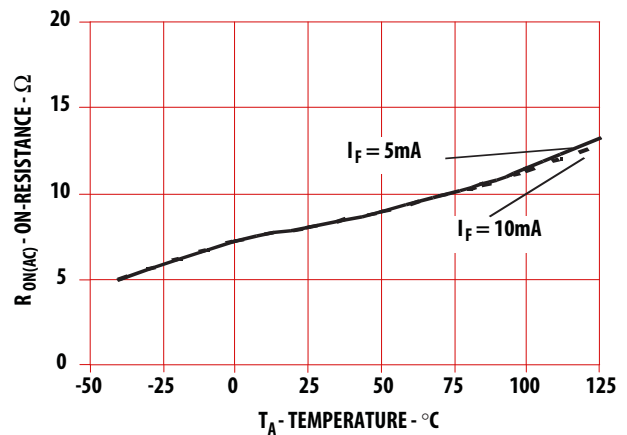

Figure 10. Typical On Resistance (AC/DC Connection) vs Temperature

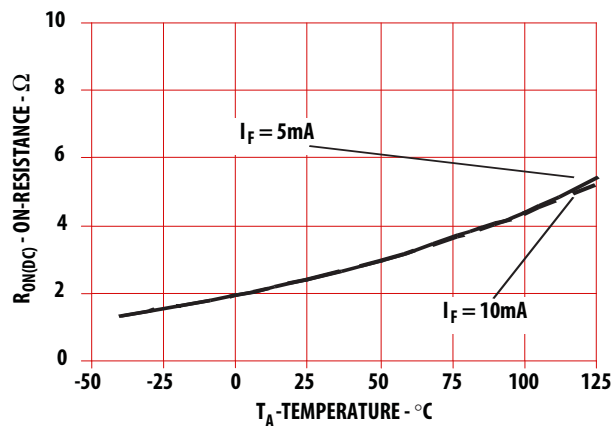

Figure 11. Typical On Resistance (DC Connection) vs Temperature

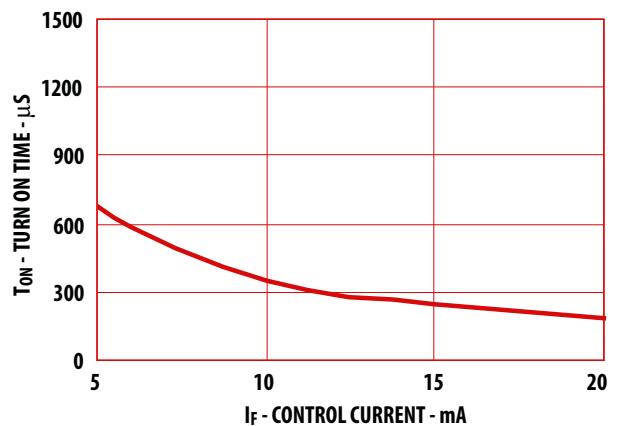
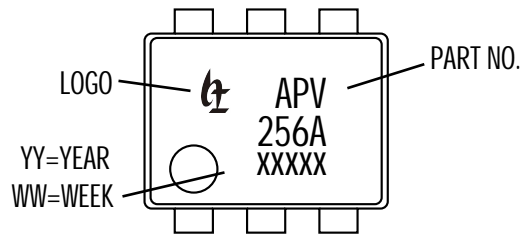

Figure 12. Typical Turn On Time vs Input Current



Dimensions and DIP-6 Package Unit: mm

Marking



Lable



Through hole terminal type

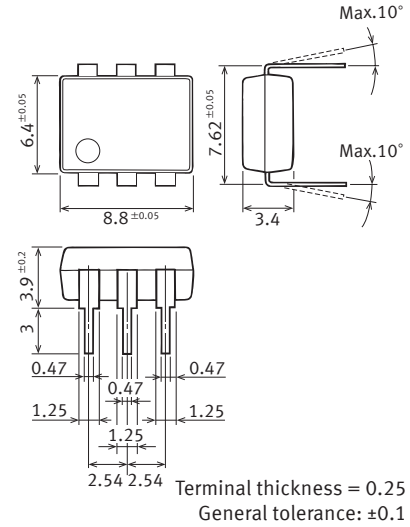

PC board pattern (Bottom view)

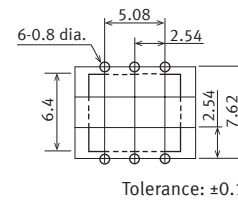

DIP Tape dimensions Unit: mm

Devices are packaged in a tube so that pin No. 1 is on the stopper B side. Observe correct orientation when mounting them on PC boards.

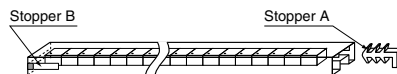



Dimensions and SMD-6 Package Unit: mm

Marking

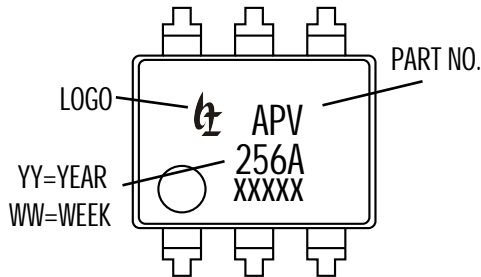

Surface mount terminal type

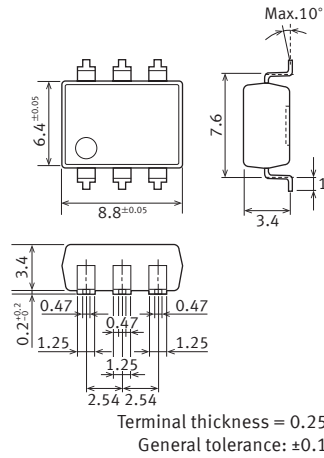

Lable

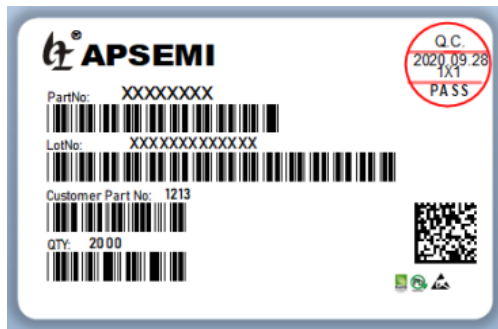

Recommended mounting pad (Top view)

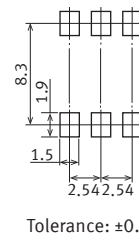

Tape dimensions (tape reel)

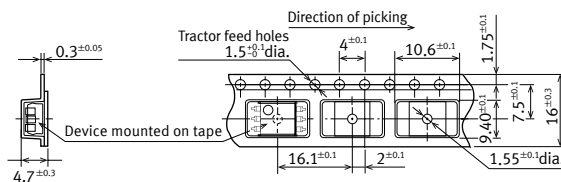
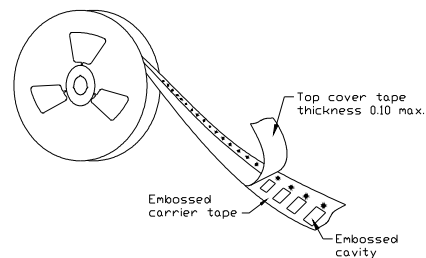
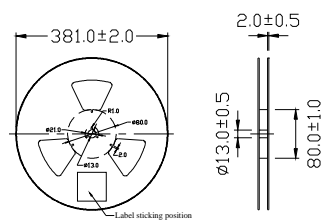



Using Methods

Examples of resistance value to control LED forward current ($I_F=5\text{mA}$)

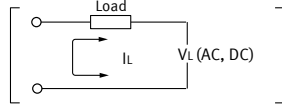
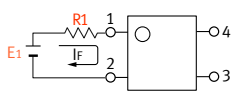

E1	R1 (Approx)
3.3V	300 Ω
5.0V	600 Ω
12V	1.9KΩ
24V	4.1KΩ

LED forward current must be more than 5mA , at I(MIN) ,and less than 30mA , at I(MAX).

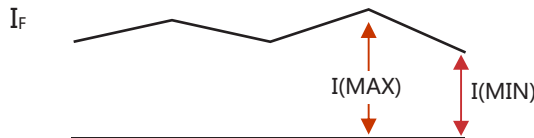

Recommended Operating Conditions

Please obey the following conditions to ensure proper device operation and resetting. Input LED current (Recommended value):

Characteristic	Symbol	Min	Typ.	Max	Unit
Forward current	I_F	5.0	7.0	30	mA

Protection Circuit

Output spike voltages:if an inductive load generates spike voltages which exceed heabsolute maximum rating, the spike voltage shall be limited.

Clamp diode is connected in parallel with the load.
Absorb capacity with external diode.

CR Snubber is connected in parallel with the load.
Absorb capacity with buffer capacity.

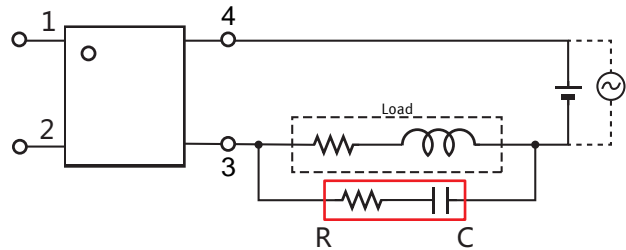
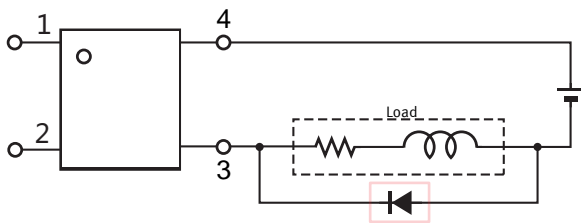

When adding diodes, buffer circuits (C-R), and other protections, they need to be installed near the MOS RELAY to be effective. Adding protection elements may result in a slow reset time, so adjust them according to the actual situation before use.

Note: When developing designs using this product, perform the expected performance of the equipment under the operating conditions recommended by the guidelines in this document. Continuous use under heavy loads (including, but not limited to, the application of high temperatures/current/voltage and significant changes in temperature, etc.) may result in deterioration of the reliability of this product.



Recommended Soldering Conditions

(a) Infrared reflow soldering :

- Peak reflow soldering : 260°C or below (package surface temperature)
- Time of peak reflow temperature : 10 sec
- Time of temperature higher than 230°C : 30-60 sec
- Time to preheat temperature from 180~190°C : 60-120 sec
- Time(s) of reflow : Two
- Flux : Rosin flux containing small amount of chlorine (The flux with a maximum chlorine content of 0.2 Wt% is recommended.)

Recommended Temperature Profile of Infrared Reflow

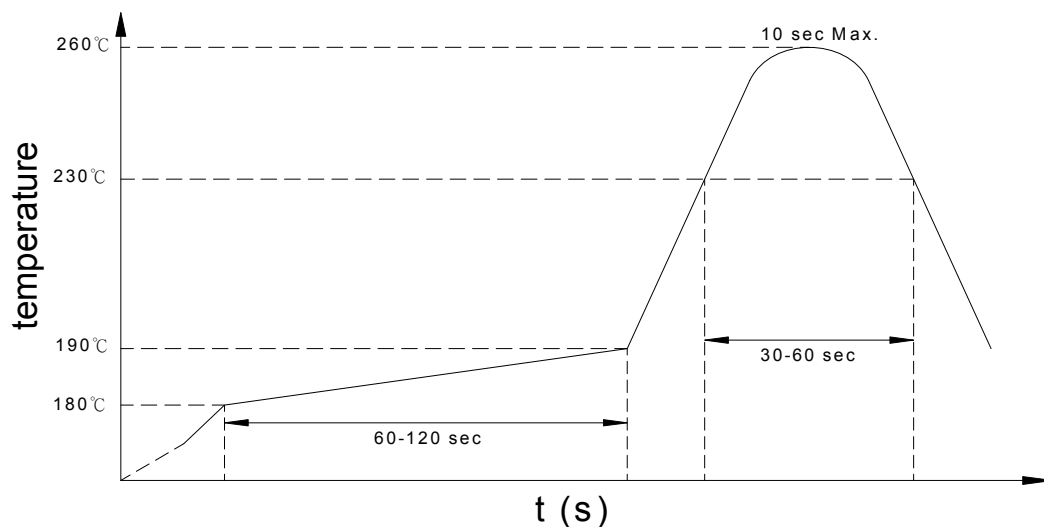

(b) Wave soldering :

- Temperature : 260°C or below (molten solder temperature)
- Time : 10 seconds or less
- Preheating conditions : 120°C or below (package surface temperature)
- Time(s) of reflow : One
- Flux : Rosin flux containing small amount of chlorine (The flux with a maximum chlorine content of 0.2 Wt% is recommended.)

(c) Cautions :

- Fluxes : Avoid removing the residual flux with freon-based and chlorine-based cleaning solvent.
- Avoid shorting between portion of frame and leads.



RESTRICTIONS ON PRODUCT USE

APSEMI Co. and its subsidiaries and affiliates (collectively "APSEMI") reserve the right to make changes to all information contained in this document relating to hardware, software, and systems (collectively "Products").

No information in this document may be reproduced without the prior written permission of APSEMI. Even with APSEMI's written permission, this document may only be reproduced if it is guaranteed to be unaltered or missing.

APSEMI assumes no responsibility for unintended uses of the product:

Unintended uses include, but are not limited to, equipment used in nuclear facilities, equipment used in the aerospace industry, medical equipment, automobiles, trains, ships, and other transportation equipment, traffic signaling equipment, equipment used for the control of combustion or explosions, safety devices, elevators and escalators, equipment used in electrical power-related applications, and equipment used in financial-related applications.

APSEMI assumes no responsibility for the product if you use it for any purpose other than the specific purpose described in this document.

- The information contained herein is provided only as a guide for the use of the product. APSEMI assumes no responsibility for infringement of third party patents or any other intellectual property rights that may result from the use of the product. This document does not grant any license, express or implied, estoppel or otherwise, to any intellectual property.

- GaAs (Gallium Arsenide) is used in products and is harmful to humans. Inadvertent ingestion or absorption of GaAs can harm the human body, so handle the product with care and do not break, cut, crush, grind, chemically dissolve, or otherwise expose GaAs in the product.

- Please be aware of environmental issues and use products in compliance with all applicable laws and regulations governing the inclusion or use of controlled substances, including but not limited to the EU RoHS Directive. APSEMI assumes no responsibility for damages or losses resulting from non-compliance with applicable laws and regulations.